

Transylvania County Schools

FY27 Budget Request to Transylvania County Board of Commissioners

Building a Stronger Tomorrow...Today

Introduction

On behalf of the Transylvania County Board of Education and our entire TCS staff, thank you. The confidence you place in our schools — through your continued partnership and your willingness to have these conversations year after year — matters more than we can fully express. We want to make sure the results we share with you today reflect the care that has gone into spending every dollar you have entrusted to us.

Our Students Are Rising

The 2024-2025 school year was a genuinely good year for our students and our district. Niche ranked TCS #2 out of 115 North Carolina school districts for having the best teachers, and #8 statewide as a best place to teach. For a small mountain district, those rankings mean something. They do not come from marketing — they come from teachers who show up every day for children in this community, and from the local support that makes it possible to keep them here.

#1 in North Carolina CTE Credential Rate	#1 in WNC ACT Performance Brevard High School	#1 in WNC Academic Growth Rosman Middle School	#2 of 115 Best Teachers in NC (Niche 2026)
--	--	---	---

Brevard High School finished the year ranked #1 in the Western Region for ACT performance among traditional public high schools. Nearly 72% of BHS students met college readiness benchmarks, and the school posted a 93.5% graduation rate — with 74.6% of students earning career certifications along the way. Rosman Middle School tied for the top spot in Western NC on the state academic growth index, finishing with a +3.19 score. Our Career and Technical Education program closed the year at an 89.29% credential attainment rate, which was recognized as the **highest in the state** at the NC CTE Director's Conference.

Some of the results we are most encouraged by came from our youngest students. TC Henderson Elementary saw a 26.3-point reading gain from 3rd to 4th grade, and its first graders grew 17% in foundational reading compared to last year. Brevard Elementary's K-3 literacy proficiency climbed from 64% to 71%. Pisgah Forest Elementary gained 13.6 points in reading proficiency between 4th and 5th grade. Rosman Elementary finished in the **top 25% of schools statewide** in both overall proficiency and math. Across the whole district, Grade 3 reading fluency improved by 10% from the beginning to the end of the year. These are the kinds of gains that tend to stick — and they tell us our early literacy work is paying off.

We are proud of what this year produced. We are also clear-eyed about the work still ahead — and we have a plan.

In May 2025, our Board of Education adopted the TCS 2025-2030 Strategic Plan. It came out of a year-long process that involved 845 community members — students, parents, teachers, local business owners, and government representatives — who shared their hopes and concerns for our schools. The four priorities they helped us identify are: Student Achievement; Human Resources and Quality Staff; Communication and Community Relations; and Safe, Innovative Learning Environments. Each request in this document connects to at least one of those priorities.

What It Takes to Keep This Going

Good results do not maintain themselves — and you helped make sure of that. When you approved the FY25 budget and increased our local salary supplement to match Henderson County, it sent a message to every teacher and staff member in this district that Transylvania County values the work they do. We heard from our people about it, and it made a difference. That decision was the right one, and we thank you.

Every request in this document is grounded in a clear purpose — protecting what this district has built and positioning our students for continued success. We are not asking for more than we need. We are asking for what we believe is necessary to keep talented people in our classrooms, meet the real needs of our students, and give our communities schools they are proud of.

We appreciate the time you give to reviewing this request, and we welcome your questions. Before we walk through the numbers, we want to take a moment to say thank you — because what you approved last year made a real and lasting difference for our students and our staff.

A Sincere Thank You — FY26 Investments That Made a Difference

Last year, you made a series of decisions that went far beyond a line item on a spreadsheet. Each one addressed something real — a safety gap, a building need, or a student who deserved better access to the programs we offer. We want to name those decisions specifically, because they deserve to be acknowledged.

When you approved the salary supplement increase to match Henderson County, you did something that had not happened in more than a decade. Our teachers and staff noticed. It sent a message that this community values the people who show up for its kids every day. Recruiting conversations got easier too. It was a meaningful show of support, and we do not take it for granted.

The approval of the Centegix CrisisAlert safety system will give our schools a level of emergency response capability they did not have before. Soon our staff will have wearable badges that can summon help in seconds, and our visitor management system has added a meaningful layer of accountability at every front entrance. In a year when we have already completed 14 threat assessments districtwide, having better tools in place matters — for our staff, our students, and the families who trust us with their children every morning.

You also funded several practical needs that had gone unaddressed for too long. The handicap accessible activity buses mean that students with mobility needs can now participate in field trips and extracurricular activities alongside their peers — something we could not guarantee before. The first bus was put into service in November and has already logged over 1,000 miles. The walk-in freezers at Rosman Elementary and TC Henderson are already

in use, supporting two of our growing schools and making it possible to serve meals properly as enrollment increases. The elevator repair at Rosman Middle and High School restored reliable access for students, staff, and visitors with mobility challenges — a repair that had nothing to do with the bond project but everything to do with basic accessibility. New bus cameras and radios to help keep our students and drivers safe. And the snow removal plows for our maintenance vehicles gave our team the tools to handle winter weather on our own, keeping hourly employees working and paid rather than calling in outside vendors.

Each of those investments reflected a willingness to look at our schools honestly and respond to what you found. That is the kind of partnership that makes this process worth doing well, and we are grateful for it. With that context in mind, here is a look at what it costs to operate Transylvania County Schools — and where we are asking for your continued support in FY27.

BUDGET AT A GLANCE

There are two major components of the Total Budget: Operating Budget and Capital Budget.

The Operating Budget pays for the day-to-day costs of operating the school system, such as salaries and benefits, purchased services, supplies and materials, maintenance, janitorial, and utilities. The primary funding sources for the operating budget are county tax dollars, fines and forfeitures, and interest income.

The Capital Improvements Budget pays for equipment, vehicles, major building improvements, and/or repairs to facilities. A full budget request summary is available on page 17.

The State budget pays for:
Salaries and Benefits
Purchased Services
Supplies & Materials
The Local budget pays for:
Salaries and Benefits
Purchased Services
Transfer to Charter Schools
Supplies & Materials
Utilities/Communication
The Federal budget pays for:
Salaries and Benefits
Purchased Services
Supplies & Materials

HOW THE STATE DETERMINES FUNDING

NCDPI allocates funds to **Local Education Agencies (LEAs)** based on total Average Daily Membership (ADM) primarily to provide local school boards with the flexibility to manage resources across their specific district needs.

Under North Carolina's "resource allocation model," the state determines the total number of positions and dollar amounts a district is entitled to based on its overall student count, then allows district leaders to distribute those resources among individual school buildings as they deem necessary. Funding formulas for the State Public School, as outlined in the State Allotment Policy Manual, are grade specific, not individual school specific. This model gives the LEA flexibility and control at the district level.

Example:

Let's say we have 4 elementary schools, and each school has one 1st grade class with 10 students. That means we have 40 first graders total across the district.

The state funds teachers based on a ratio of about 1 teacher for every 18 students. With 40 students, the state would fund a little more than 2 teachers.

But because those students are spread across 4 different schools, we still have to staff 4 separate classrooms. So the funding for the teachers in about two of those classrooms has to come from local dollars.

Attrition Management

When an employee retires or resigns, we don't treat the vacancy as an automatic refill. Instead, we take a step back and look at how many students that position serves and whether the work can be absorbed elsewhere in a smarter way. If another employee can take on those responsibilities without shortchanging the students they already serve — or if we have an employee whose current role reaches fewer students — we redirect that person into the higher-impact position and leave the other seat vacant. We've already applied this approach at the central office level: when our Federal Programs Director retired, a fellow director absorbed those duties rather than adding a new hire. When an office staff member retired shortly after, a colleague stepped up and took on that workload as well. As we navigate the position losses tied to our enrollment decline, we'll apply this same intentional approach in our schools — always asking whether a vacancy represents a genuine gap or an opportunity to do more with what we have.

What It Costs to Operate Each School

One thing that is easy to lose in a budget conversation is a sense of what it actually costs to keep a school running day to day. The table below breaks that down by school, so you can see where the dollars go and how the investment is distributed across our community. These figures reflect operating costs paid only by local funds and do not include state or federal funds.

School	Local Funds FY26 Operating Cost By School	Student ADM
Brevard Elementary School	\$2,386,218	510
TC Henderson Elementary	\$542,748	116

Pisgah Forest Elementary School	2,002,551	428
Rosman Elementary School	\$1,539,344	329
Brevard Middle School	\$2,217,779	474
Rosman Middle School	\$874,946	187
Brevard High School	\$3,738,408	799
Rosman High School	\$1,197,788	256
Davidson River School	\$290,089	62
Total District Operating Budget	\$14,789,871	3161

***Based off of the state funding of \$4,679.00 per pupil*

With that full picture in mind, what follows are our specific funding requests for FY27. Each one is tied to a real need — for our students, our staff, or our buildings — and each connects directly to the priorities in our 2025-2030 Strategic Plan. We have done our best to be specific about what we are asking for, what it will cost, and why it matters. The FY27 budget request is built from an increase in three specific, documented cost drivers: Exceptional Children, Child Nutrition and Charter Schools. None of them are discretionary.

DEPARTMENTS THAT RECEIVE LOW FUNDING FROM THE STATE

EXCEPTIONAL CHILDREN

Under the federal Individuals with Disabilities Education Act (IDEA), every public school district is legally required to provide a Free Appropriate Public Education to every eligible student with a disability — regardless of whether state or federal funding is adequate to cover the cost. North Carolina funds Exceptional Children programs at a flat rate of \$5,593.34 per student, but only up to a cap of 13% of a district's total enrollment. That cap was established in 1993 and has remained largely unchanged, even as EC populations across the state have grown considerably. For every student above that 13% threshold, the state provides zero funding while the district bears full financial and legal responsibility for their services. Transylvania County Schools currently serves more than 19% of its students through EC programs — nearly 6.5 percentage points above the state cap — meaning hundreds of students are served entirely on local dollars.

What makes this challenge even more difficult is the restrictive nature of both state and federal EC funding. These dollars come with very specific rules about what they can and cannot cover. The day-to-day essentials that make a meaningful difference for students with disabilities — wheelchairs and adaptive equipment, Augmentative and Alternative Communication (AAC) devices, weighted vests and sensory tools, 1:1 paraprofessional support, and the physical modifications needed to make classrooms truly accessible — often fall outside what state and federal funds will allow. Those costs land on the local budget. Additionally, Transylvania County Schools operates the SELF program at Brevard Elementary School, a specialized environment designed to serve students with significant trauma histories and

behavioral needs. Best practice for this program calls for a full-time therapist embedded in the program to provide intensive individual and group therapy — a position that has historically been funded locally. While a behavior support grant helped cover a portion of that salary this year for the first time, that grant is not guaranteed and is evaluated on an annual basis, making it an unreliable funding source for a critical staffing need.

The federal government compounds this problem further. When Congress passed IDEA in 1975, it committed to covering 40% of the per-pupil cost of educating students with disabilities. Today, federal funding covers only about 13% of that cost — less than one-third of the original promise. This is not a challenge unique to Transylvania County. North Carolina districts of all sizes are struggling with the same structural gap: one district with an ADM of 13,862 carries a \$600,000 annual shortfall in payroll costs alone; another with an ADM of 20,610 used \$1.8 million from fund balance to cover EC costs; and yet another district of similar size estimated \$9.8 million in unfunded EC expenses for FY26. Transylvania County Schools is not alone in facing this reality, but with an EC enrollment rate well above the state average, the financial pressure on local taxpayers to fill this gap is among the most significant in western North Carolina.

Local Funding applied: Spent \$568,299 in local funds for 2024-25.

CHILD NUTRITION

The Child Nutrition Department operates as a separate enterprise fund — meaning it is designed to be self-sustaining through its own revenue streams rather than supported by the district's general operating budget. Funding comes primarily from federal USDA meal reimbursements paid through the National School Lunch Program and School Breakfast Program, student meal fees, and a required \$45,000 allotment from the State Public School Fund. This is the structure every school district in North Carolina operates under. By design, revenue generated by the program must stay within the fund and cannot be transferred elsewhere.

In practice, that model has not been sufficient to cover the program's actual costs — and it has not been for some time.

Rising food costs, increased labor costs, supply chain pressures, aging food service equipment, and federal reimbursement rates that have not kept pace with the real cost of serving meals have created a persistent and growing gap between what the program earns and what it costs to run. As a result, Transylvania County Schools has had to supplement Child Nutrition with local operating dollars each year to keep the program running. This is not an unusual situation — districts across North Carolina and the country face the same challenge — but it is an honest and important part of the financial picture we are presenting to commissioners.

The local investment has been significant and consistent:

- **FY24:** \$442,631
- **FY25:** \$350,882
- **FY26:** estimated minimum of \$350,000

These are not one-time fixes. They are recurring obligations that the district has absorbed year after year, and they must be recognized as a real, ongoing cost in the local budget.

The district is committed to continuing to examine operational efficiencies, participation rates, and cost controls to strengthen the program's long-term sustainability. But the structural pressures driving this gap — food inflation, labor costs, and stagnant federal reimbursement rates — are largely outside the district's control.

What is within our control is making sure every student has access to a healthy meal each school day. A fed student is a ready learner. The investment in Child Nutrition is an investment in student success, behavior, and overall well-being — and for many TCS families, school meals are not a convenience. They are a necessity

CHARTER SCHOOL FUNDING

Under North Carolina law (G.S. 115C-218.105), local school administrative units are required to transfer a proportionate share of their local current expense fund appropriation — on a per-pupil basis — to any charter school enrolling students who reside within the district. This is not a choice or a policy preference. It is a statutory obligation, and the dollar amount follows the student automatically, regardless of the impact on the district's own operating budget.

The way this works in practice is straightforward: for every Transylvania County student who enrolls in a charter or virtual school, TCS must transfer its full local per-pupil allocation to that school. The district receives less local funding to serve the students who remain in its buildings, while its fixed costs — facilities, transportation, administrative infrastructure — do not decrease proportionally when students leave.

Charter school enrollment among Transylvania County students has grown steadily in recent years, and with it, the district's required payments. Based on district records, local charter school payments have been as follows:

- FY21: \$1,088,525
- FY22: \$1,162,170
- FY23: \$1,162,645
- FY24: \$1,259,392
- FY25: \$1,313,583

This trend matters to the FY27 budget conversation for a simple reason: as charter enrollment grows, so does the required transfer — and the district has no mechanism to reduce or control that cost. Every dollar transferred to a charter school is a dollar that cannot be used for the students and programs TCS is directly responsible for operating. For the FY2026 school year we are expected to spend approximately \$1,440,000.00.

To be clear, this is not a critique of charter schools or the families who choose them. Families have the right to choose the educational environment they believe is best for their children, and TCS respects that. We just want everyone to understand that this payment is a real and growing line item in the district's local budget — one that increases automatically as charter enrollment grows, with no corresponding reduction in the fixed costs of running our schools.

ADDITIONAL OPERATIONAL REQUESTS

ATHLETIC REIMBURSEMENT REQUEST

Last year, we asked you to reimburse these operating costs to our schools, and we want to explain why this request continues to matter. With the increase in officials' pay, our middle and high schools simply cannot generate enough revenue at the gate and through concessions to cover the cost of officials and SROs while still maintaining the full range of sports we offer our students. We request that these costs be reimbursed annually, in arrears, to allow athletic budgets to be used for equipment, facilities, and student enrichment as intended.

Estimated annual reimbursement to be calculated based on prior year's actual expenses:

	Security/SRO	Officials
School	24/25 Totals	24/25 Totals
Rosman Middle School	\$2,055.00	\$4,738.00
Rosman High School	\$7,830.00	\$14,069.00
Brevard Middle School	\$5,760.00	\$6,974.00
Brevard High School	\$18,080.50	\$29,893.00
Total	\$33,725.50	\$55,674.00
Overall Total Reimbursement based on 24/25 Totals		\$89,399.50

THE REALITY OF STATE FUNDING IN FY27

Before we walk through the budget options, we want to make sure the state funding picture is clear — because it shapes everything that follows. Based on planning allotments released by NCDPI, Transylvania County Schools is projected to receive at least \$883,591 less in state funding next year than we received at the start of this year. The primary reason is enrollment. As our student count declines, nearly every formula-driven allotment declines with it — affecting funding for classroom teachers, instructional support, CTE, transportation, at-risk students, and more. These are not cuts we can appeal or negotiate around. They are the automatic result of how North Carolina's funding model works: fewer students mean fewer dollars, even when our fixed costs — buildings, buses, staff, and services — don't decrease at the same rate. This is not something we caused or could have prevented. It is the structural reality we are asking you to help us navigate.

The table below shows exactly where those losses fall. Driven by a projected enrollment decline of 102 students — bringing our ADM to 3,059 — the state's formula-based allotments decrease across nearly every program category. The most significant impact is in classroom teacher positions. Beyond classroom teachers, we are also losing a central office position, an instructional support position, and a reduction in Career and Technical Education months — adding another \$183,000 in position-related losses. The remaining \$273,000 comes from reduced program funding across transportation, at-risk student services, disadvantaged student supports, teacher assistants, academically gifted programs, classroom materials, and textbooks. In short, this is not one big cut in one place — it is a series of smaller reductions spread across almost every part of how we operate, and together they add up fast.

TRANSYLVANIA COUNTY SCHOOLS - STATE ONLY											
2026-27 ADM 3059											
LE A	Program Report Code	Program Report Code Description	2025-26 Initial Allotment			2026-27 Planning Allotment			Difference	Type	Dollar Value
			Position	Month	Amount	Position	Month	Y-T-D Allotment			
880	001	Classroom Teachers	142.5	0	11,551,620.00	136.5	0	11,123,931.00	-6.00	Position	-\$427,689.00
880	002	Central Office Administration	0	0	747,651.00	0	0	679,950.00	-1.00	Position	-\$67,701.00
880	003	Non-Instructional Support Personnel	0	0	1,065,602.00	0	0	1,031,220.00			-\$34,382.00
880	004	K-5 Program Enhancement Teachers	7	0	574,203.00	7	7	579,208.00			
880	005	School Building Administration	0	140	1,467,552.00	0	139	1,436,532.00	-1.00	Month	-\$31,020.00
880	006	School Health Personnel-Position	8	0	666,056.00	8	0	711,720.00			
880	007	Instructional Support Personnel - Certified	8	0	693,400.00	7	0	619,346.00	-1.00	Position	-\$74,054.00
880	013	Career Technical Education - Months of	0	193	1,556,545.00	0	191	1,515,164.00	-2.00	Months	-\$41,381.00
880	014	Career Technical Education - Program	0	0	60,895.00	0	0	59,412.00			-\$1,483.00
880	019	Small County Supplemental Funding	0	0	1,548,200.00	0	0	1,548,200.00			\$0.00
880	024	Disadvantage Students Supplemental	0	0	138,688.00	0	0	134,048.00			-\$4,640.00
880	027	Teacher Assistants	0	0	1,000,930.00	1.25	0	953,880.00			-\$47,050.00
880	034	Academically or Intellectually Gifted	0	0	189,295.00	0	0	183,478.00			-\$5,817.00
880	056	Transportation of Pupils	0	0	1,302,295.00	0	0	1,287,286.00			-\$15,009.00
880	061	Classroom Materials/Instructional	0	0	99,607.00	0	0	116,787.00			
880	069	At-Risk Student Services/Alternative	0	0	926,628.00	0	0	902,010.00			-\$24,618.00
880	071	Supplemental Teacher Compensation	0	0	656,627.00	0	0	686,956.00			
880	131	Textbook & Digital Resources	0	0	117,429.00	0	0	113,642.00			-\$3,787.00
880	015	School Technology	0	0	37,256.00	0	0	36,491.00			-\$765.00
880	032	Children with Disabilities	0	0	2,617,129.00	0	0	2,512,934.00			-\$104,195.00
Grand Total Minimum State Potential Loss											-\$883,591.00

Disclaimer: 2026-27 Planning Allotments based on 3059 ADM, a loss of 102 students from 2025-26.

OPERATIONAL BUDGET REQUEST SUMMARY

Transylvania County Schools is requesting a local appropriation of \$14,859,228 under Option A, \$15,784,371 under Option B and \$16,136,462 under Option C. This is built on the FY26 current allocation of \$14,567,871, plus the three documented cost drivers that are unavoidable in the coming year.

The three funding options are outlined below, reflecting the district's request for FY27.

Option A represents the responsible minimum aligned with county fiscal guidance.

Option B represents funding with no state salary increase, only projected increase in benefit costs. This amount covers the increase in benefits — insurance and retirement — for locally paid positions only. It does *not* account for any raise from the NC General Assembly, the loss of state funding, or increases to our other cost drivers beyond our control. If Option B is selected and the legislature approves a salary increase, the district would need to return to the Board of Commissioners for additional local funding to cover those locally paid positions.

Option C addresses the full scope of operational needs — including salary, potential salary increases, estimated state funding loss, and other cost drivers.

It is important to note that while \$291,357 (Option A) will cover the benefit and retirement increases for our locally funded positions, it does not address the state allotment losses the district is absorbing this year. Beyond the \$160,314 reduction in program funding — which affects supplies for Career and Technical Education, resources for disadvantaged students, academically or intellectually gifted learners, transportation funding, at-risk student services, and textbooks and digital resources — the district is also facing a \$723,277 loss in position allotments. *Combined, these reductions place a significant burden on the district's fund balance.* And because of rising inflation and increasing utility costs, the true financial impact of absorbing these losses will be considerably higher than the numbers on paper suggest.

Option A represents an approximate 2% increase to the local funding request. Option B represents an approximate 7.5% increase to the local funding request, and Option C represents an approximate 10% increase to the local funding request. This option accounts for the projected 5.8% state salary increase as well as \$883,591 in estimated lost funding from the state, for a total request of \$1,568,591. Approving this amount would allow the district to retain nearly all current positions.

Regardless of which option is approved, the district can absorb some position losses this year through attrition. However, there will come a point when that approach is no longer sufficient to sustain our workforce.

OPTION A: Responsible Minimum — Aligned with County Fiscal Guidance:

Operating Cost	FY27 Amount	
FY26 Local Appropriation (Current Year Base)		\$14,567,871*
Responsible Minimum - aligned with county fiscal guidance	\$291,357	
Total estimated FY27 local budget request		\$291,357
TOTAL FY27 LOCAL BUDGET REQUEST		\$14,859,228

**It does not account for any raise from the NC General Assembly, the loss of state funding, or increases to our other cost drivers beyond our control. If Option B is selected and the legislature approves a salary increase, the district would need to return to the Board of Commissioners for additional local funding to cover those locally paid positions.*

OPTION B WITH NO SALARY INCREASE, ONLY PROJECTED INCREASE IN BENEFIT COSTS:

Operating Cost	FY27 Amount	
FY26 Local Appropriation (Current Year Base)		\$14,567,871*
Estimated minimum decrease in state funding per TCS Planning Allotments Projected by NCDPI	\$883,591	
Estimated projected increase in benefit costs (WITH NO SALARY INCREASE)	\$122,909	
Estimated minimum increase in funding for EC	\$85,000	
Estimated minimum increase in funding to Charter Schools	<u>\$125,000</u>	
Total estimated FY27 local additional minimum funding needed		<u>\$1,216,500</u>
Total estimated FY27 local budget request		\$15,784,371
TOTAL FY27 ESTIMATED LOCAL BUDGET SHORTFALL		\$1,216,500

**This appropriation includes the following additional financial support required for the following for 24/25: Child Nutrition \$350,882, Exceptional Children \$568,299, Charter School Payments \$1,313,583 and Athletic Program Costs of \$89,400, which total \$2,322,164. *It does not account for any raise from the NC General Assembly, the loss of state funding, or increases to our other cost drivers beyond our control. If Option B is selected and the legislature approves a salary increase, the district would need to return to the Board of Commissioners for additional local funding to cover those locally paid positions.*

OPTION C WITH 5.8% AVERAGE SALARY INCREASE:

Operating Cost	FY27 Amount	
FY2025–26 Local Appropriation (Current Year Base)		\$14,567,871*
Estimated minimum decrease in state funding per TCS Planning Allotments Projected by NCDPI	\$883,591	
To maintain current local salaries with an average projected increase of 5.8%, including benefits	\$475,000	
Estimated minimum increase in funding for EC	\$85,000	
Estimated minimum increase in funding to Charter Schools	\$125,000	
Total estimated 2026/2027 local additional minimum funding needed		<u>\$1,568,591</u>
Total estimated 2026/2027 local budget request		\$16,136,462
TOTAL FY27 ESTIMATED LOCAL BUDGET SHORTFALL		\$1,568,591

**This appropriation includes the following additional financial support required for the following for 24/25: Child Nutrition \$350,882, Exceptional Children \$568,299, Charter School Payments \$1,313,583 and Athletic Program Costs of \$89,400, which total \$2,322,164.*

FURNITURE, FIXTURES & EQUIPMENT (FFE) FY27 REQUEST

FF&E (Furniture, Fixtures & Equipment)- schools	\$167,650
Savings for Turf Replacement	\$100,000
Cafeteria Table Replacement Rotation	\$10,000
Classroom desks/table replacement Rotation	\$183,408
Computer Equipment - systemwide	\$775,463
Operational Maintenance Supplies – System Wide	\$220,000
TOTAL	\$1,456,521

FY27 FF&E & CAPITAL OUTLAY REQUESTS (FUND 4)

Classroom Desk replacement:

Last year, I asked to begin a classroom desk rotation. Great idea and thought process. However, when we actually began pricing science lab tables, desk and chairs versus tables, the amount was much more than anticipated. We were able to purchase classroom sets for 6 schools (elementary and middle). I now have a better breakdown of the cost to furnish one classroom a year on a rotation basis.

These prices will give each school:

A standard furniture package for a single classroom typically provides comprehensive workstations for one teacher and up to 30 students. The teacher's area is equipped with a Hexy highback mesh chair, a Cora 30-inch bar stool, an "Instruct" pedestal desk with a D-shape top, and an "All Terrain" mobile instructor's desk. For students, the setup generally includes 30 chairs and 30 desks, such as the Intellect Wave or Ruckus models, which often feature adjustable heights and integrated storage like bag hooks or book boxes. In specialized science classrooms, the layout shifts to accommodate 32 students using 16 fixed-height tables with chemical-resistant phenolic tops and 32 large Intellect Wave chairs.

Transylvania County Schools Furniture Investment Summary

School	Student Desk Cost (Incl. Tax)	Teacher Desk Cost (Incl. Tax)	Grand Total (Incl. Tax & labor)
Brevard Elementary School	\$13,185.07	\$3,757.01	\$16,942.08
Pisgah Forest Elementary	\$12,757.27	\$3,757.01	\$16,514.28
Rosman Elementary School	\$13,048.16	\$3,757.01	\$16,805.17
TC Henderson Elementary	\$12,564.06	\$3,757.01	\$16,321.07
Brevard Middle School	\$11,520.68	\$3,757.01	\$15,277.69
Rosman Middle School	\$12,270.28	\$3,757.01	\$16,027.29
Davidson River School	\$11,520.68	\$3,757.01	\$15,277.69
Brevard High School (Classroom)	\$13,624.52	\$3,997.20	\$17,621.72
Brevard High School (Science)	\$18,264.71	N/A	\$18,264.71
Rosman High School (Classroom)	\$12,094.45	\$3,997.20	\$16,091.65
Rosman High School (Science)	\$18,264.71	N/A	\$18,264.71
TOTAL COST OF CLASSROOM FURNITURE			\$183,408.06

Product and Quantity Breakdown by School (Detailed)

Elementary Schools

- **Brevard Elementary:**
 - **Teacher:** 1 Hexy Highback Chair, 1 Cora 30" Bar Stool, 1 Instruct Pedestal Desk, 1 All Terrain Mobile Instructors Desk.
 - **Student:** 29 Intellect Wave 4-Leg Desks (Adj. Height), 1 Intellect Wave ADA Desk, 30 Intellect Wave 4-Leg Chairs (Large).
- **Rosman Elementary:**
 - **Teacher:** 1 Hexy Highback Chair, 1 Cora 30" Bar Stool, 1 Instruct Pedestal Desk, 1 All Terrain Mobile Instructors Desk.
 - **Student:** 30 Intellect Wave 4-Leg Desks (Adj. Height) with Bag Hooks, 30 Intellect Wave 4-Leg Chairs (Large).
- **Pisgah Forest Elementary:**
 - **Teacher:** 1 Hexy Highback Chair, 1 Cora 30" Bar Stool, 1 Instruct Pedestal Desk, 1 All Terrain Mobile Instructors Desk.
 - **Student:** 30 Intellect Wave 4-Leg Desks (Adj. Height) with Book Boxes, 30 Intellect Wave 4-Leg Chairs (Large).
- **TC Henderson Elementary:**
 - **Teacher:** 1 Hexy Highback Chair, 1 Cora 30" Bar Stool, 1 Instruct Pedestal Desk, 1 All Terrain Mobile Instructors Desk.
 - **Student:** 30 Intellect Wave 4-Leg Chairs (Medium), 30 Intellect Wave Desks (Adj. Height) with Book Boxes.

Middle Schools

- **Brevard Middle:**
 - **Teacher:** 1 Hexy Highback Chair, 1 Cora 30" Bar Stool, 1 Instruct Pedestal Desk, 1 All Terrain Mobile Instructors Desk.
 - **Student:** 30 Intellect Wave 4-Leg Desks (Adj. Height) with Bag Hooks, 30 Intellect Wave 4-Leg Chairs (Large).
- **Rosman Middle:**
 - **Teacher:** 1 Hexy Highback Chair, 1 Cora 30" Bar Stool, 1 Instruct Pedestal Desk, 1 All Terrain Mobile Instructors Desk.
 - **Student:** 29 Ruckus Post-Leg Desks (Fixed), 1 Ruckus Post-Leg Desk (Adj. Height), 30 Book Bag Hooks, 30 Cogni Cantilever Chairs (Medium).

High Schools & Davidson River

- **Davidson River School:**
 - **Teacher:** 1 Hexy Highback Chair, 1 Cora 30" Bar Stool, 1 Instruct Pedestal Desk, 1 All Terrain Mobile Instructors Desk.
 - **Student:** 30 Intellect Wave 4-Leg Desks (Adj. Height) with Bag Hooks, 30 Intellect Wave 4-Leg Chairs (Large).
- **Brevard & Rosman High School (Classrooms):**
 - **Teacher:** 1 Hexy Highback Chair, 1 Cora 30" Bar Stool, 1 Instruct Pedestal Desk, 1 All Terrain Mobile Instructors Desk.
 - **Student:** 29 Ruckus Post-Leg Desks (Fixed), 1 Ruckus Post-Leg Desk (Adj. Height), 30 Book Bag Hooks, 30 Cogni Cantilever Chairs (Large).
- **Brevard & Rosman High School (Science Rooms):**
 - **Student:** 16 Fixed Height Tables (60"x30" with Phenolic Top), 32 Intellect Wave 4-Leg Chairs (Large).

Plant Ops Truck

- Our maintenance department travels throughout the district daily making minor repairs and checking heating and air conditioning systems across all of our schools. The vehicles used to support this work are

aging out, and we need to begin working newer ones into the fleet to ensure our team can continue to respond reliably to the needs of our buildings.

Transportation Truck

- We are requesting the replacement of the Transportation Director's current vehicle, a 2007 Dodge truck with over 200,000 miles. This vehicle is used daily for road checks, responding to bus breakdowns, and travel throughout the district — duties that log significantly more miles than any other position in the system. The truck has reached the end of its useful life and should be sold. A 4x4 replacement is necessary to safely conduct road checks during winter weather conditions. A quote for the replacement vehicle is attached.

Dish Machines

- **Priority #1:** We are requesting funding to replace the 30-year-old dishmachine at BHS. Our repair provider, RB Services, has confirmed that required replacement parts are obsolete and no longer available. This machine is critical to our daily operations. It is used to wash and sanitize all cookware and serving equipment for approximately 400 student lunches each day, as well as meals prepared for the county daycare, Hillview Children's Center, Boys and Girls Club, Teen Center, and Rise and Shine programs. Because the unit cannot be repaired if it fails, replacement is necessary to ensure uninterrupted meal service and maintain required health and safety standards. Quote: \$28,216.14
- **Priority #2:** We are requesting funding to replace the approximately 30-year-old dishmachine at TCH. Similar to the BHS unit, our repair provider has confirmed that replacement parts are obsolete and no longer available, making repairs unreliable or impossible. Quote: \$21,665.34. The TCH kitchen serves 120 students breakfast and lunch daily. The dishmachine is essential for washing and sanitizing cookware and reusable trays, which we use to reduce waste and control costs. Because the unit cannot be repaired if it fails, replacement is necessary to maintain meal service operations, sanitation standards, and our waste-reduction efforts.
- **Priority #3:** The RHS dishmachine is comparable in age and usage to the units at BHS and TCH, placing it in a similar condition. As a primary food production site for summer feeding programs, RHS depends on fully functioning equipment year-round to ensure uninterrupted food service operations. Quote: \$43,080.52

Child Nutrition Maintenance

- Our Child Nutrition department outsources for all routine maintenance needs on kitchen equipment and as needed equipment repairs. These services are very expensive but necessary to keep the operation moving daily. This cost is estimated at a minimum of \$60,000 annually.

Generators

- **PlantOps**
 - To ensure full operational capability, we request funding to purchase and install a replacement dual-feed generator to supply reliable power to our bus garage, gas pumps, and food warehouse. Our current generator is over 30 years old and no longer functions reliably, putting our critical infrastructure at risk. During Hurricane Helene, our bus garage served as a vital backup fuel source for emergency responders supporting our community's hurricane response efforts. To continue serving as the primary fuel source for emergency responders in the county, maintain the functionality of our mechanical equipment, and safeguard our food supply during extended power outages, it is essential that we have a dependable and fully powered facility. This investment will significantly enhance our community's resilience and emergency preparedness.
- **MEC**

- The generator at the Morris Education Center has failed on multiple occasions, including just before the most recent ice storm. Fortunately, the vendor was able to bring out a portable generator, which kept operations running throughout the storm. What makes this more than just a building issue is what MEC houses — the connectivity hub for every school in the district. If power goes out at MEC and the generator fails, every school loses its network connection, regardless of whether those individual schools still have power. That connectivity supports both our internet and VoIP systems, meaning all communication — phones included — would go dark district-wide, with mobile service being the only option left. A building going dark is one problem; the entire district going offline is another.

Computer Equipment Increase

- Transylvania County Schools has long been committed to staying at the forefront of education technology, and maintaining that standard requires a consistent, planned approach to device replacement. The \$500,000 annual allocation covers the recurring cost of replacing end user devices on a regular cycle, using State Contract Pricing 204A to ensure we are getting the best available rates. That breaks down as follows: 650 Chromebooks with cases at \$346,243.63, 150 teacher laptops at \$135,000, Google licensing at \$25,000, and Microsoft licensing at \$28,000. Due to the increase in price, the total needed is \$534,243.63.
- Beyond the standard device cycle, we also need to begin planning for the replacement of technology that was originally purchased with ESSER funds. Those one-time funds allowed us to make meaningful investments — K-2 Chromebooks and interactive panels across the district — that we would not have been able to afford otherwise. The challenge now is that those devices, like all technology, have a limited life expectancy and warranty period. Over 90% of our interactive panels are either out of warranty or approaching the end of it, and the K-2 Chromebooks are in a similar position. Rather than wait until devices fail, we are asking to get ahead of this with a planned replacement cycle. The K-2 Chromebooks would be spread over four years at \$65,000 annually, and the interactive panel replacement cycle would run \$176,219.70 per year — for a recurring total of approximately \$241,219.70.
- It is also worth noting that the overall cost of technology continues to rise. Hardware, software licensing, and support agreements have all increased in recent years, meaning the same dollars we allocated in the past no longer stretch as far as they once did. Staying current with technology is not optional — it directly supports student learning and teacher effectiveness — and we want to be transparent that keeping pace with that commitment will require continued and, in some cases, increased investment over time making the new requested technology total: \$775,463.33

BHS Baseball Light Switch

While completing the softball field lighting project, a separate but related issue was identified with the baseball field lights: turning them on and off currently requires manually flipping a breaker in the electrical panel. That's not a safe practice, and it's not a sustainable long-term solution. The softball project addressed this same need with the installation of proper switching controls, so we know what the fix looks like. We've received a quote of \$11,055.03 to install a correct on/off switch for the baseball field lights. Fortunately, \$2,912 in unspent funds remained from the softball project, which we've applied toward this work. We are requesting \$8,143.03 to complete the baseball field lighting controls and bring that system up to the same standard.

Detection Heads at BHS

The fire alarm detection heads at Brevard High School are approaching the end of their useful life. Even with regular cleaning, dust accumulation is an ongoing challenge that gradually degrades sensor performance and shortens lifespan. We are requesting approval to replace all detection heads at this time. The new heads and loop

system have been selected to ensure compatibility with the new CTE building once construction is complete, allowing for a seamless integration rather than a costly retrofit down the road.

Capital Line Item Requests

Plant Ops Truck	\$49,687.10
Transportation Truck	\$49,687.10
Dish machine at BHS	\$28,216.14
Dish machine at TCHES	\$21,665.34
Dish machine at RHS	\$43,080.52
Child Nutrition Ongoing Maintenance	\$60,000.00
Generator for Child Nutrition, Transportation, and Plant Ops	\$125,817.28
BHS Baseball Field Light Switch	\$8,143.03
Generator for MEC	\$43,469.13
Detection Head Replacement at BHS	\$33,812.00
TOTAL	\$463,577.64

Summary

Transylvania County Schools is not a district that takes what it has been given for granted. Every investment this board has made — in our people, our buildings, our technology, and our safety — has been put to work. And at the end of the day, every line in this budget connects back to a person — a teacher who chose to stay, a student who got what they needed, a parent who felt their child was safe. Our students are performing at levels that get noticed across the state, and that does not happen by accident. It happens because this community has chosen, year after year, to invest in them. We are asking you to make that choice again, and we will continue to make sure it counts.

FULL FY27 BUDGET REQUEST

Operational	Option A	Option B	Option C
FY26 Local Appropriation (Current Year Base)	\$14,567,871	\$14,567,871	\$14,567,871
To Maintain Current Local Salaries with an increase to benefits		\$122,909	
To Maintain Current Local Salaries with a 5% Increase, Including Benefits			\$475,000
Responsible Minimum — Aligned with County Fiscal Guidance	\$291,357		
Minimum Amount of Decrease in State Funding		\$883,591	\$883,591
Minimum Increase in EC Funding		\$85,000	\$85,000
Minimum Expected Increase in Charter School Funding		\$125,000	\$125,000
Subtotal	\$291,357	\$1,216,500	\$1,568,591
Total Operational Requested	\$14,859,228	\$15,784,371	\$16,136,462
FF&E (Furniture, Fixtures, and Equipment) - schools	\$167,650	\$167,650	\$167,650
Savings for Turf Replacement	\$100,000	\$100,000	\$100,000
System Wide Daily Operational Maintenance	\$220,000	\$220,000	\$220,000
Cafeteria Table Replacement Rotation	\$10,000	\$10,000	\$10,000
Classroom desks/table Replacement Rotation	\$183,408	\$183,408	\$183,408
Computer Equipment - Systemwide	\$775,463	\$775,463	\$775,463
Plant Ops Truck (Maintenance Dept.)	\$49,687	\$49,687	\$49,687
Transportation Dept. Truck	\$49,687	\$49,687	\$49,687
Dish Machine at BHS	\$28,216	\$28,216	\$28,216
Dish Machine at TCHES	\$21,665	\$21,665	\$21,665
Dish Machine at RHS	\$43,081	\$43,081	\$43,081
Child Nutrition Ongoing maintenance	\$60,000	\$60,000	\$60,000
Generator for Child Nutrition, Transportation, and Plant Ops	\$125,817	\$125,817	\$125,817
Generator for MEC	\$43,469	\$43,469	\$43,469
BHS Baseball Field Light Switch	\$8,143.03	\$8,143.03	\$8,143.03
Detection Head Replacement - BHS	\$33,812	\$33,812	\$33,812
Total Capital Outlay Requested	\$1,920,098	\$1,920,098	\$1,920,098
Full Requested Funding, Operational & Capital	\$16,779,326	\$17,704,469	\$18,056,560

ATTACHMENTS INDEX

Attachment A: Classroom Desk/Furniture Quote.....	18
Attachment B: Plant Ops Truck Quote	98
Attachment C: Transportation Truck Quote.....	99
Attachment D: BHS Dish machine Quote.....	100
Attachment E: RHS Dish Machine Quote	106
Attachment F: TCHES Dish Machine Quote.....	110
Attachment G: Plant Ops Generator Quote.....	116
Attachment H: MEC Generator Quote.....	117
Attachment I: Technology Equipment Quote.....	118
Attachment J: BHS Baseball Light Switch	121
Attachment K: BHS Detection Head Replacement	122



Transylvania County Schools

PRICE PROPOSAL

Date: 2/25/2026

Quote Number: 1252-25915

Valid For 30 Days

Prepared by: Michelle Stevenson

Confidential

© 2026 PBI, Inc..The information in this transmittal is proprietary to PBI, Inc.. It is provided on the condition that it remains in confidence between PBI, Inc. and the recipient of this quote. Do Not Copy, Distribute nor Share the Contents of this proposal without the written permission of PBI, Inc..



Project Scope

Bill To

Kerry Putnam
 Transylvania County Schools
 225 Rosenwald Lane
 Brevard, NC 28712

Project Investment

Project Total	\$15,870.80
Tax (6.75%)	\$1,071.28
Grand Total	\$16,942.08

Install To

Mike Kirst
 Transylvania County Schools
 Brevard Elementary School
 399 Greenville Hwy
 Brevard, NC 28712

Payment Schedule

75% Deposit / Net 30 Days

75% Deposit / Net 30 Days	\$12,706.56
---------------------------	-------------

Price Summary by Phase

Option	Phase / TAG	Price	Tax	Total
Transylvania County Schools Brevard Elementary Furniture Full Classroom	Teacher	\$3,519.45	\$237.56	\$3,757.01
	Labor	\$928.00	\$62.64	\$990.64
	Classroom	\$11,423.35	\$771.07	\$12,194.42
		\$15,870.80	\$1,071.28	\$16,942.08
Grand Total		\$15,870.80	\$1,071.28	\$16,942.08

BILL TO
 Kerry Putnam
 Transylvania County Schools
 225 Rosenwald Lane
 Brevard, NC 28712

INSTALL TO
 Mike Kirst
 Transylvania County Schools
 Brevard Elementary School
 399 Greenville Hwy
 Brevard, NC 28712

Salesperson
 Michelle Stevenson

Payment Terms
 75% Deposit / Net 30 Days



All KI Pricing per NC State Contract. Shipping from factory included.

Transylvania County Schools Brevard Elementary Furniture Full Classroom

Labor

LINE #	QTY	UNIT	PART # / DESCRIPTION	PRICE EA	EXT PRICE
1	1.00	EA	Furniture Labor / Installation / Labor to receive, deliver and install during normal business hours.	\$928.00	\$928.00

Teacher



LINE #	QTY	UNIT	PART # / DESCRIPTION	PRICE EA	EXT PRICE
2	1.00	EA	1203.BK2.MB.FE3.AR4 / Hexy, Highback, Mesh Back, Standard Synchro w/Seat Depth Adj, Height/Adjustable Arms	\$466.65	\$466.65
			 <p>OPTIONS</p> <ul style="list-style-type: none"> CH1 Standard Cylinder (Cylinder Height Option) FC1 Black Frame (Frame Color Selection) BT2 5 Star Polished Aluminum Base(For Any Frame Color) (Base Selection) CS6 Hard Floor And Carpet Casters (Caster Selection) MC21 Nickel Mesh (Hexy Mesh Back Colors) US Upholstered Seat (Hexy Upholstered Seat Material Selection) FG2 Fabric/Vinyl Grade 2 (Fabric Grade Selections) ELEMENT Element Color Selection (Fabric Grade 2 Selection) CHARCOAL Element Charcoal (Element Color Selection) UC Back Attached To Seat, Base Separate (Packaging Options) 		
3	1.00	EA	1191SW19S2.US.UB.AR0 / Cora 30" Bar Stool, Armless	\$299.70	\$299.70
			 <p>OPTIONS</p> <ul style="list-style-type: none"> FC2 Silver Frame (Frame Information) GL2 Performance Multi-Surface Glides (Caster/Glide Option Selection) ~ No Moisture Barrier (Moisture Barrier) USU Single Upholstered (Fabric Option) ~ No Ballistic Nylon Option (Ballistic Nylon Option Selection) FG2 Fabric/Vinyl Grade 2 (CORA Single Upholstered) ELEMENT Element Color Selection (Fabric Grade 2 Selection) CHARCOAL Element Charcoal (Element Color Selection) AC Fully Assembled In Carton (Packaging Options) 		

Transylvania County Schools Brevard Elementary Furniture Full Classroom

Teacher

LINE #	QTY	UNIT	PART # / DESCRIPTION	PRICE EA	EXT PRICE
4	1.00	EA	INTDLR2460 / Instruct Teacher Pedestal Desk,D-Shape Top,T-Leg,Laminate Mod. Panel,BBF Ped Right,24Dx60Wx29H,74P edge	\$913.14	\$913.14
			OPTIONS /USP Nickel Arc (Pull Option) LAMG1 Laminate Grade 1 (Laminate) LAMGRD1STD Grade 1 Ki Standard Laminates (Laminate Finish) /LDR Designer White D354-60 (Grade 1 Ki standard laminates) /EDR Designer White Edge (Edge Color) /SX Starlight Silver Metallic (Paint Color) /KA Key Alike (Lock Option) /SCL Satin Chrome (Lock Color)		
5	1.00	EA	ATMTDP2466-74P-WSL-S3 / All Terrain Mobile Instructors Desk,Steel Door,Aluminum Bow Tie Pull,Left Worksurface,66"	\$1,839.96	\$1,839.96
			 OPTIONS LAMG1 Laminate Grade 1 (Laminate) LAMGRD1STD Grade 1 Ki Standard Laminates (Laminate Finish) /LDR Designer White D354-60 (Grade 1 Ki standard laminates) /SX Starlight Silver Metallic (Unit Color) /KA Key Alike (Lock Option) /SCL Satin Chrome (Lock Color) /L107 Key Alike Lock #107 (National Key Alike) /EDR Designer White Edge (Edge Color)		

Classroom

LINE #	QTY	UNIT	PART # / DESCRIPTION	PRICE EA	EXT PRICE
6	29.00	EA	IWD4FH/A / Intellect Wave 4-Leg Desk,Adj Height,Hard Plastic Top,Ships Assembled	\$274.17	\$7,950.93
			 OPTIONS /SB Steel Book Box (Book Storage Option) /SBL Black (Steel Book Box Color) /CH Chrome (Intellect Wave Frame Color) /LWL White Nebula (Plastic Top Surface Color) /NG Nylon Glides (Glide Option) /SFT Straight Front Top (Top Shape) INFO Top Size 19-3/8"X26-3/4" (Top Size) INFO Height Range 22-34" (Height Range)		
7	1.00	EA	IWD4FH/ADA / Intellect Wave 4-Leg Desk,ADA Adjustable Height,Hard Plastic Top,Straight Front,Ships Assembled	\$308.94	\$308.94
			 OPTIONS /SB Steel Book Box (Book Storage Option) /SBL Black (Steel Book Box Color) /CH Chrome (Intellect Wave Frame Color) /LWL White Nebula (Plastic Top Surface Color) /NG Nylon Glides (Glide Option) INFO Top Size 20"X36" (Top Size) INFO Height Range 22-34" (Height Range)		

PBI, Inc. **Attachment A**
 123 Sweeten Creek Rd, Suite A
 Asheville, NC 28803
 Phone: (828) 277-7001
 Fax: (828) 277-7003
 pbiasheville.com



QUOTATION

1252-25915

VALID UNTIL 3/27/2026

Transylvania County Schools Brevard Elementary Furniture Full Classroom

Classroom

LINE #	QTY	UNIT	PART # / DESCRIPTION	PRICE EA	EXT PRICE
8	30.00	EA	IW418 / Intellect Wave 4-Leg Chair, Large, 18"H	\$105.45	\$3,163.48
					
OPTIONS /NG Nylon Glides (Glide Option) /RCK Racked (Carton Code Option) /CH Chrome (Intellect Wave Frame Color) /NFR No Fire Retardant (Shell Color) /PND Nordic (Shell NFR)					

CUSTOMER SIGN OFF

subtotal	\$15,870.80
sales tax	\$1,071.28
total	\$16,942.08

 Authorized Signature

 Accepted Date

 Print Name



PBI Terms and Conditions

Disclaimer:

-PO and/or Signature along with materials deposit required to process order. We appreciate this opportunity and look forward to a successful project!

-All prices are based on information discussed. Budgets can vary based on the final selections of materials and accessories. PBI's services are figured for normal business hours unless discussed otherwise. PBI has included all known elements within this good faith estimate. If unknown issues arise, they will be discussed with the team to determine best plan of action to proceed.

-PBI orders are specific to each client/project. Any orders changed or cancelled after order processing will result in change fees, full materials charge, or applicable restocking fees.

-75% deposit required unless client has been approved for credit terms

-PBI to invoice based on progress of job which will include materials delivered to site and/or stored materials in PBI warehouse.

-Storage Fee of \$350 per week will be charged on goods held over 30 days unless arrangements have been made.

-PBI accepts credit card transactions with a 4% transaction fee.

-PBI, Inc reserves the right to raise the material price on this proposal by the percentage increase of any publicly announced tariff that may take place before this proposal is accepted by the (customer/client). If PBI, Inc is awarded the contract, any price increase of material due to tariffs during the performance of the contract through no fault of the Contractor, the contract sum shall be equitably adjusted by change order in accordance with the procedures of the contract documents. A change in price of an item of material shall be considered significant when the price of an item increases 10% or more between the date of the contract and the date of installation.

-Phased installations, trips, and material deliveries to be determined prior to signed proposal. Any additions or changes will result in additional charges. Job sites must have clear and safe access for delivery.

Additional Terms for Flooring-Construction- Windows and Doors

-Any unforeseen circumstances will be discussed with the owner/project manager and additional charges may apply.

- Flooring installation requires-All HVAC and Lighting to be in operation prior to installation. PBI excludes the following unless otherwise noted in proposal: Floor Leveling; Moisture Mitigation; Nights/Weekends; Floor Protection; Expansion Joints; Dumpsters.

-PBI cannot accept responsibility for costs that may be associated with delays and product production and delivery to job site.

-All products delivered to jobsite must be inspected at time of delivery and will require signature. PBI will only accept responsibility for noted missing or damaged items.

PBI, Inc. **Attachment A**
 123 Sweeten Creek Rd, Suite A
 Asheville, NC 28803
 Phone: (828) 277-7001
 Fax: (828) 277-7003
 pbiasheville.com



DEPOSIT INVOICE

1252-25915-0

Due Upon Receipt
 2/25/2026

Bill To

Kerry Putnam
 Transylvania County Schools
 225 Rosenwald Lane
 Brevard, NC 28712

Install To / End User

Mike Kirst
 Transylvania County Schools
 Brevard Elementary School
 399 Greenville Hwy
 Brevard, NC 28712

PROJECT #	SALESPERSON	QUOTE NAME	PROJECT NAME
1252	Michelle Stevenson	Transylvania County Schools Brevard Elementary	Transylvania County Schools Brevard Elementary Furniture Full Classroom

Deposit Details Summarized by Phase

Option	Phase	Price	Tax	Total	Deposit Amount
Transylvania County Schools Brevard Elementary Furniture Full Classroom	Teacher	\$3,519.45	\$237.56	\$3,757.01	\$2,817.76
	Labor	\$928.00	\$62.64	\$990.64	\$742.98
	Classroom	\$11,423.35	\$771.07	\$12,194.42	\$9,145.82
Total		\$15,870.80	\$1,071.28	\$16,942.08	\$12,706.56

Order Total	\$15,870.80
Sales Tax	\$1,071.28
Total	\$16,942.08
75% Deposit Due	\$12,706.56



Transylvania County Schools

PRICE PROPOSAL

Date: 2/25/2026

Prepared For: Amanda Lewis

Quote Number: 1256-25917

Valid For 30 Days

Prepared by: Michelle Stevenson

Confidential

© 2026 PBI, Inc..The information in this transmittal is proprietary to PBI, Inc.. It is provided on the condition that it remains in confidence between PBI, Inc. and the recipient of this quote. Do Not Copy, Distribute nor Share the Contents of this proposal without the written permission of PBI, Inc..



Project Scope

Bill To

Kerry Putnam
 Transylvania County Schools
 225 Rosenwald Lane
 Brevard, NC 28712

Install To

Amanda Lewis
 Transylvania County Schools
 Pisgah Forest Elementary School
 1160 Ecusta Rd
 Brevard, NC 28712

Project Investment

Project Total	\$15,470.05
Tax (6.75%)	\$1,044.23
Grand Total	\$16,514.28

Payment Schedule

75% Deposit / Net 30 Days

75% Deposit / Net 30 Days	\$12,385.71
---------------------------	-------------

Price Summary by Phase

Option	Phase / TAG	Price	Tax	Total
Transylvania County Schools Pisgah Forest Elementary Furniture Full Classroom	Classroom	\$15,470.05	\$1,044.23	\$16,514.28
		\$15,470.05	\$1,044.23	\$16,514.28
Grand Total		\$15,470.05	\$1,044.23	\$16,514.28

PBI, Inc. **Attachment A**
 123 Sweeten Creek Rd, Suite A
 Asheville, NC 28803
 Phone: (828) 277-7001
 Fax: (828) 277-7003
 pbiasheville.com



QUOTATION

1256-25917

VALID UNTIL 3/27/2026

BILL TO

Kerry Putnam
 Transylvania County Schools
 225 Rosenwald Lane
 Brevard, NC 28712

INSTALL TO

Amanda Lewis
 Transylvania County Schools
 Pisgah Forest Elementary School
 1160 Ecusta Rd
 Brevard, NC 28712



Salesperson
 Michelle Stevenson

Payment Terms
 75% Deposit / Net 30 Days

All KI Pricing per NC State Contract. Shipping from factory is included.



Transylvania County Schools Pisgah Forest Elementary Furniture Full Classroom

Classroom

LINE #	QTY	UNIT	PART # / DESCRIPTION	PRICE EA	EXT PRICE
1	30.00	EA	IWD4FH/A / Intellect Wave 4-Leg Desk,Adj Height,Hard Plastic Top,Ships Assembled	\$262.77	\$7,883.10
			 <p>OPTIONS</p> <ul style="list-style-type: none"> /SB Steel Book Box (Book Storage Option) /SBL Black (Steel Book Box Color) /BL Black (Intellect Wave Frame Color) /LWL White Nebula (Plastic Top Surface Color) /NG Nylon Glides (Glide Option) /SFT Straight Front Top (Top Shape) INFO Top Size 19-3/8"X26-3/4" (Top Size) INFO Height Range 22-34" (Height Range) 		
2	30.00	EA	IW418 / Intellect Wave 4-Leg Chair, Large, 18"H	\$105.45	\$3,163.50
			 <p>OPTIONS</p> <ul style="list-style-type: none"> /NG Nylon Glides (Glide Option) /RCK Racked (Carton Code Option) /CH Chrome (Intellect Wave Frame Color) /NFR No Fire Retardant (Shell Color) /PND Nordic (Shell NFR) 		
3	1.00	EA	1203.BK2.MB.FE3.AR4 / Hexy, Highback, Mesh Back, Standard Synchro w/Seat Depth Adj, Height/Adjustable Arms	\$466.65	\$466.65
			 <p>OPTIONS</p> <ul style="list-style-type: none"> CH1 Standard Cylinder (Cylinder Height Option) FC1 Black Frame (Frame Color Selection) BT2 5 Star Polished Aluminum Base (For Any Frame Color) (Base Selection) CS6 Hard Floor And Carpet Casters (Caster Selection) MC21 Nickel Mesh (Hexy Mesh Back Colors) US Upholstered Seat (Hexy Upholstered Seat Material Selection) FG2 Fabric/Vinyl Grade 2 (Fabric Grade Selections) ELEMENT Element Color Selection (Fabric Grade 2 Selection) CHARCOAL Element Charcoal (Element Color Selection) UC Back Attached To Seat, Base Separate (Packaging Options) 		

Transylvania County Schools Pisgah Forest Elementary Furniture Full Classroom

Classroom

LINE #	QTY	UNIT	PART # / DESCRIPTION	PRICE EA	EXT PRICE
4	1.00	EA	1191SW19S2.US.UB.ARO / Cora 30" Bar Stool, Armless	\$299.70	\$299.70
			 <p>OPTIONS</p> <p>FC2 Silver Frame (Frame Information)</p> <p>GL2 Performance Multi-Surface Glides (Caster/Glide Option Selection)</p> <p>~ No Moisture Barrier (Moisture Barrier)</p> <p>USU Single Upholstered (Fabric Option)</p> <p>~ No Ballistic Nylon Option (Ballistic Nylon Option Selection)</p> <p>FG2 Fabric/Vinyl Grade 2 (CORA Single Upholstered)</p> <p>ELEMENT Element Color Selection (Fabric Grade 2 Selection)</p> <p>CHARCOAL Element Charcoal (Element Color Selection)</p> <p>AC Fully Assembled In Carton (Packaging Options)</p>		
5	1.00	EA	INTDLR2460 / Instruct Teacher Pedestal Desk,D-Shape Top,T-Leg,Laminate Mod. Panel,BBF Ped Right,24Dx60Wx29H,74P edge	\$913.14	\$913.14
			<p>OPTIONS</p> <p>/USP Nickel Arc (Pull Option)</p> <p>LAMG1 Laminate Grade 1 (Laminate)</p> <p>LAMGRD1STD Grade 1 Ki Standard Laminates (Laminate Finish)</p> <p>/LDR Designer White D354-60 (Grade 1 Ki standard laminates)</p> <p>/EDR Designer White Edge (Edge Color)</p> <p>/SX Starlight Silver Metallic (Paint Color)</p> <p>/KA Key Alike (Lock Option)</p> <p>/SCL Satin Chrome (Lock Color)</p>		
6	1.00	EA	ATMTDP2466-74P-WSL-S3 / All Terrain Mobile Instructors Desk,Steel Door,Aluminum Bow Tie Pull,Left Worksurface,66"	\$1,839.96	\$1,839.96
			 <p>OPTIONS</p> <p>LAMG1 Laminate Grade 1 (Laminate)</p> <p>LAMGRD1STD Grade 1 Ki Standard Laminates (Laminate Finish)</p> <p>/LDR Designer White D354-60 (Grade 1 Ki standard laminates)</p> <p>/SX Starlight Silver Metallic (Unit Color)</p> <p>/KA Key Alike (Lock Option)</p> <p>/SCL Satin Chrome (Lock Color)</p> <p>/L107 Key Alike Lock #107 (National Key Alike)</p> <p>/EDR Designer White Edge (Edge Color)</p>		
7	1.00	EA	Furniture Labor / Installation / Labor to receive, deliver and install during normal business hours.	\$904.00	\$904.00

PBI, Inc. **Attachment A**
123 Sweeten Creek Rd, Suite A
Asheville, NC 28803
Phone: (828) 277-7001
Fax: (828) 277-7003
pbiasheville.com



QUOTATION

1256-25917

VALID UNTIL 3/27/2026

Transylvania County Schools Pisgah Forest Elementary Furniture Full Classroom

CUSTOMER SIGN OFF

subtotal	\$15,470.05
sales tax	\$1,044.23
total	\$16,514.28

Authorized Signature

Accepted Date

Print Name



PBI Terms and Conditions

Disclaimer:

-PO and/or Signature along with materials deposit required to process order. We appreciate this opportunity and look forward to a successful project!

-All prices are based on information discussed. Budgets can vary based on the final selections of materials and accessories. PBI's services are figured for normal business hours unless discussed otherwise. PBI has included all known elements within this good faith estimate. If unknown issues arise, they will be discussed with the team to determine best plan of action to proceed.

-PBI orders are specific to each client/project. Any orders changed or cancelled after order processing will result in change fees, full materials charge, or applicable restocking fees.

-75% deposit required unless client has been approved for credit terms

-PBI to invoice based on progress of job which will include materials delivered to site and/or stored materials in PBI warehouse.

-Storage Fee of \$350 per week will be charged on goods held over 30 days unless arrangements have been made.

-PBI accepts credit card transactions with a 4% transaction fee.

-PBI, Inc reserves the right to raise the material price on this proposal by the percentage increase of any publicly announced tariff that may take place before this proposal is accepted by the (customer/client). If PBI, Inc is awarded the contract, any price increase of material due to tariffs during the performance of the contract through no fault of the Contractor, the contract sum shall be equitably adjusted by change order in accordance with the procedures of the contract documents. A change in price of an item of material shall be considered significant when the price of an item increases 10% or more between the date of the contract and the date of installation.

-Phased installations, trips, and material deliveries to be determined prior to signed proposal. Any additions or changes will result in additional charges. Job sites must have clear and safe access for delivery.

Additional Terms for Flooring-Construction- Windows and Doors

-Any unforeseen circumstances will be discussed with the owner/project manager and additional charges may apply.

- Flooring installation requires-All HVAC and Lighting to be in operation prior to installation. PBI excludes the following unless otherwise noted in proposal: Floor Leveling; Moisture Mitigation; Nights/Weekends; Floor Protection; Expansion Joints; Dumpsters.

-PBI cannot accept responsibility for costs that may be associated with delays and product production and delivery to job site.

-All products delivered to jobsite must be inspected at time of delivery and will require signature. PBI will only accept responsibility for noted missing or damaged items.

PBI, Inc. **Attachment A**
 123 Sweeten Creek Rd, Suite A
 Asheville, NC 28803
 Phone: (828) 277-7001
 Fax: (828) 277-7003
 pbiasheville.com



DEPOSIT INVOICE

1256-25917-0

Due Upon Receipt
 2/25/2026

Bill To

Kerry Putnam
 Transylvania County Schools
 225 Rosenwald Lane
 Brevard, NC 28712

Install To / End User

Amanda Lewis
 Transylvania County Schools
 Pisgah Forest Elementary School
 1160 Ecusta Rd
 Brevard, NC 28712

PROJECT #	SALESPERSON	QUOTE NAME	PROJECT NAME
1256	Michelle Stevenson	Transylvania County Schools Pisgah Forest Elementary	Transylvania County Schools Pisgah Forest Elementary Furniture Full Classroom

Deposit Details Summarized by Phase

Option	Phase	Price	Tax	Total	Deposit Amount
Transylvania County Schools Pisgah Forest Elementary Furniture Full Classroom	Classroom	\$15,470.05	\$1,044.23	\$16,514.28	\$12,385.71
Total		\$15,470.05	\$1,044.23	\$16,514.28	\$12,385.71

Order Total	\$15,470.05
Sales Tax	\$1,044.23
Total	\$16,514.28

75% Deposit Due \$12,385.71



Transylvania County Schools

PRICE PROPOSAL

Date: 2/25/2026

Quote Number: 1258-25918

Valid For 30 Days

Prepared by: Michelle Stevenson

Confidential

© 2026 PBI, Inc..The information in this transmittal is proprietary to PBI, Inc.. It is provided on the condition that it remains in confidence between PBI, Inc. and the recipient of this quote. Do Not Copy, Distribute nor Share the Contents of this proposal without the written permission of PBI, Inc..



Project Scope

Bill To

Kerry Putnam
 Transylvania County Schools
 225 Rosenwald Lane
 Brevard, NC 28712

Install To

Bob Dinsdale
 Transylvania County Schools
 Rosman Elementary School
 167 Rosman School Rd
 Rosman, NC 28772

Project Investment

Project Total	\$15,742.55
Tax (6.75%)	\$1,062.62
Grand Total	\$16,805.17

Payment Schedule

75% Deposit / Net 30 Days

75% Deposit / Net 30 Days	\$12,603.88
---------------------------	-------------

Price Summary by Phase

Option	Phase / TAG	Price	Tax	Total
Transylvania County Schools- Rosman Elem. School - Classroom	Classroom	\$15,742.55	\$1,062.62	\$16,805.17
		\$15,742.55	\$1,062.62	\$16,805.17
Grand Total		\$15,742.55	\$1,062.62	\$16,805.17

PBI, Inc. **Attachment A**
 123 Sweeten Creek Rd, Suite A
 Asheville, NC 28803
 Phone: (828) 277-7001
 Fax: (828) 277-7003
 pbiasheville.com



QUOTATION

1258-25918

VALID UNTIL 3/27/2026

BILL TO
 Kerry Putnam
 Transylvania County Schools
 225 Rosenwald Lane
 Brevard, NC 28712

INSTALL TO
 Bob Dinsdale
 Transylvania County Schools
 Rosman Elementary School
 167 Rosman School Rd
 Rosman, NC 28772



Salesperson
 Michelle Stevenson

Payment Terms
 75% Deposit / Net 30 Days

All KI pricing per NC State Contract. Shipping from factory is included.



Transylvania County Schools- Rosman Elem. School -Classroom

Classroom

LINE #	QTY	UNIT	PART # / DESCRIPTION	PRICE EA	EXT PRICE
1	30.00	EA	IW418 / Intellect Wave 4-Leg Chair, Large, 18"H	\$105.45	\$3,163.50
			 <p>OPTIONS</p> <ul style="list-style-type: none"> /NG Nylon Glides (Glide Option) /RCK Racked (Carton Code Option) /CH Chrome (Intellect Wave Frame Color) /NFR No Fire Retardant (Shell Color) /PND Nordic (Shell NFR) 		
2	30.00	EA	IWD4FH/A / Intellect Wave 4-Leg Desk, Adj Height, Hard Plastic Top, Ships Assembled	\$271.32	\$8,139.60
			 <p>OPTIONS</p> <ul style="list-style-type: none"> /SBBH Steel Book Box And Bag Hooks (Book Storage Option) /SBL Black (Steel Book Box Color) /BL Black (Intellect Wave Frame Color) /LWL White Nebula (Plastic Top Surface Color) /NG Nylon Glides (Glide Option) /SFT Straight Front Top (Top Shape) INFO Top Size 19-3/8"X26-3/4" (Top Size) INFO Height Range 22-34" (Height Range) 		
3	1.00	EA	1203.BK2.MB.FE3.AR4 / Hexy, Highback, Mesh Back, Standard Synchro w/Seat Depth Adj, Height/Adjustable Arms	\$466.65	\$466.65
			 <p>OPTIONS</p> <ul style="list-style-type: none"> CH1 Standard Cylinder (Cylinder Height Option) FC1 Black Frame (Frame Color Selection) BT2 5 Star Polished Aluminum Base (For Any Frame Color) (Base Selection) CS6 Hard Floor And Carpet Casters (Caster Selection) MC21 Nickel Mesh (Hexy Mesh Back Colors) US Upholstered Seat (Hexy Upholstered Seat Material Selection) FG2 Fabric/Vinyl Grade 2 (Fabric Grade Selections) ELEMENT Element Color Selection (Fabric Grade 2 Selection) CHARCOAL Element Charcoal (Element Color Selection) UC Back Attached To Seat, Base Separate (Packaging Options) 		

Transylvania County Schools- Rosman Elem. School -Classroom

Classroom

LINE #	QTY	UNIT	PART # / DESCRIPTION	PRICE EA	EXT PRICE
4	1.00	EA	1191SW19S2.US.UB.ARO / Cora 30" Bar Stool, Armless	\$299.70	\$299.70
			 <p>OPTIONS</p> <p>FC2 Silver Frame (Frame Information)</p> <p>GL2 Performance Multi-Surface Glides (Caster/Glide Option Selection)</p> <p>~ No Moisture Barrier (Moisture Barrier)</p> <p>USU Single Upholstered (Fabric Option)</p> <p>~ No Ballistic Nylon Option (Ballistic Nylon Option Selection)</p> <p>FG2 Fabric/Vinyl Grade 2 (CORA Single Upholstered)</p> <p>ELEMENT Element Color Selection (Fabric Grade 2 Selection)</p> <p>CHARCOAL Element Charcoal (Element Color Selection)</p> <p>AC Fully Assembled In Carton (Packaging Options)</p>		
5	1.00	EA	INTDLR2460 / Instruct Teacher Pedestal Desk,D-Shape Top,T-Leg,Laminate Mod. Panel,BBF Ped Right,24Dx60Wx29H,74P edge	\$913.14	\$913.14
			<p>OPTIONS</p> <p>/USP Nickel Arc (Pull Option)</p> <p>LAMG1 Laminate Grade 1 (Laminate)</p> <p>LAMGRD1STD Grade 1 Ki Standard Laminates (Laminate Finish)</p> <p>/LDR Designer White D354-60 (Grade 1 Ki standard laminates)</p> <p>/EDR Designer White Edge (Edge Color)</p> <p>/SX Starlight Silver Metallic (Paint Color)</p> <p>/KA Key Alike (Lock Option)</p> <p>/SCL Satin Chrome (Lock Color)</p>		
6	1.00	EA	ATMTDP2466-74P-WSL-S3 / All Terrain Mobile Instructors Desk,Steel Door,Aluminum Bow Tie Pull,Left Worksurface,66"	\$1,839.96	\$1,839.96
			 <p>OPTIONS</p> <p>LAMG1 Laminate Grade 1 (Laminate)</p> <p>LAMGRD1STD Grade 1 Ki Standard Laminates (Laminate Finish)</p> <p>/LDR Designer White D354-60 (Grade 1 Ki standard laminates)</p> <p>/SX Starlight Silver Metallic (Unit Color)</p> <p>/KA Key Alike (Lock Option)</p> <p>/SCL Satin Chrome (Lock Color)</p> <p>/L107 Key Alike Lock #107 (National Key Alike)</p> <p>/EDR Designer White Edge (Edge Color)</p>		
7	1.00	EA	Furniture Labor / Installation / Labor to receive, deliver and install during normal business hours. Furniture contract price includes shipping from the manufacturer.	\$920.00	\$920.00

PBI, Inc. **Attachment A**
123 Sweeten Creek Rd, Suite A
Asheville, NC 28803
Phone: (828) 277-7001
Fax: (828) 277-7003
pbiasheville.com



QUOTATION

1258-25918

VALID UNTIL 3/27/2026

Transylvania County Schools- Rosman Elem. School -Classroom

CUSTOMER SIGN OFF

subtotal	\$15,742.55
sales tax	\$1,062.62
total	\$16,805.17

Authorized Signature

Accepted Date

Print Name



PBI Terms and Conditions

Disclaimer:

-PO and/or Signature along with materials deposit required to process order. We appreciate this opportunity and look forward to a successful project!

-All prices are based on information discussed. Budgets can vary based on the final selections of materials and accessories. PBI's services are figured for normal business hours unless discussed otherwise. PBI has included all known elements within this good faith estimate. If unknown issues arise, they will be discussed with the team to determine best plan of action to proceed.

-PBI orders are specific to each client/project. Any orders changed or cancelled after order processing will result in change fees, full materials charge, or applicable restocking fees.

-75% deposit required unless client has been approved for credit terms

-PBI to invoice based on progress of job which will include materials delivered to site and/or stored materials in PBI warehouse.

-Storage Fee of \$350 per week will be charged on goods held over 30 days unless arrangements have been made.

-PBI accepts credit card transactions with a 4% transaction fee.

-PBI, Inc reserves the right to raise the material price on this proposal by the percentage increase of any publicly announced tariff that may take place before this proposal is accepted by the (customer/client). If PBI, Inc is awarded the contract, any price increase of material due to tariffs during the performance of the contract through no fault of the Contractor, the contract sum shall be equitably adjusted by change order in accordance with the procedures of the contract documents. A change in price of an item of material shall be considered significant when the price of an item increases 10% or more between the date of the contract and the date of installation.

-Phased installations, trips, and material deliveries to be determined prior to signed proposal. Any additions or changes will result in additional charges. Job sites must have clear and safe access for delivery.

Additional Terms for Flooring-Construction- Windows and Doors

-Any unforeseen circumstances will be discussed with the owner/project manager and additional charges may apply.

- Flooring installation requires-All HVAC and Lighting to be in operation prior to installation. PBI excludes the following unless otherwise noted in proposal: Floor Leveling; Moisture Mitigation; Nights/Weekends; Floor Protection; Expansion Joints; Dumpsters.

-PBI cannot accept responsibility for costs that may be associated with delays and product production and delivery to job site.

-All products delivered to jobsite must be inspected at time of delivery and will require signature. PBI will only accept responsibility for noted missing or damaged items.

PBI, Inc. **Attachment A**
 123 Sweeten Creek Rd, Suite A
 Asheville, NC 28803
 Phone: (828) 277-7001
 Fax: (828) 277-7003
 pbiasheville.com



DEPOSIT INVOICE

1258-25918-0

Due Upon Receipt
 2/25/2026

Bill To

Kerry Putnam
 Transylvania County Schools
 225 Rosenwald Lane
 Brevard, NC 28712

Install To / End User

Bob Dinsdale
 Transylvania County Schools
 Rosman Elementary School
 167 Rosman School Rd
 Rosman, NC 28772

PROJECT #	SALESPERSON	QUOTE NAME	PROJECT NAME
1258	Michelle Stevenson	Transylvania County Schools- Rosman Elem. School -	Transylvania County Schools Rosman Elementary Furniture Full Classroom

Deposit Details Summarized by Phase

Option	Phase	Price	Tax	Total	Deposit Amount
Transylvania County Schools- Rosman Elem. School -Classroom	Classroom	\$15,742.55	\$1,062.62	\$16,805.17	\$12,603.88
Total		\$15,742.55	\$1,062.62	\$16,805.17	\$12,603.88

Order Total	\$15,742.55
Sales Tax	\$1,062.62
Total	\$16,805.17
75% Deposit Due	\$12,603.88



Transylvania County Schools

PRICE PROPOSAL

Date: 2/25/2026

Quote Number: 1259-25919

Valid For 30 Days

Prepared by: Michelle Stevenson

Confidential

© 2026 PBI, Inc..The information in this transmittal is proprietary to PBI, Inc.. It is provided on the condition that it remains in confidence between PBI, Inc. and the recipient of this quote. Do Not Copy, Distribute nor Share the Contents of this proposal without the written permission of PBI, Inc..



Project Scope

Bill To

Kerry Putnam
 Transylvania County Schools
 225 Rosenwald Lane
 Brevard, NC 28712

Install To

Packy Chapman
 Transylvania County Schools
 T C Henderson Elementary School
 11839 Rosman Hwy
 Lake Toxaway, NC 28747

Project Investment

Project Total	\$15,289.05
Tax (6.75%)	\$1,032.02
Grand Total	\$16,321.07

Payment Schedule

75% Deposit / Net 30 Days

75% Deposit / Net 30 Days	\$12,240.81
---------------------------	-------------

Price Summary by Phase

Option	Phase / TAG	Price	Tax	Total
Transylvania County Schools TC Henderson Elementary	Teacher	\$3,519.45	\$237.56	\$3,757.01
	Classroom	\$11,769.60	\$794.46	\$12,564.06
		\$15,289.05	\$1,032.02	\$16,321.07
Grand Total		\$15,289.05	\$1,032.02	\$16,321.07

BILL TO
 Kerry Putnam
 Transylvania County Schools
 225 Rosenwald Lane
 Brevard, NC 28712

INSTALL TO
 Packy Chapman
 Transylvania County Schools
 T C Henderson Elementary School
 11839 Rosman Hwy
 Lake Toxaway, NC 28747



Salesperson
 Michelle Stevenson

Payment Terms
 75% Deposit / Net 30 Days

All KI and Exempris Pricing per NC State Contract. Shipping from factory included.

Transylvania County Schools TC Henderson Elementary

Teacher



LINE #	QTY	UNIT	PART # / DESCRIPTION	PRICE EA	EXT PRICE
1	1.00	EA	1203.BK2.MB.FE3.AR4 / Hexy, Highback, Mesh Back, Standard Synchro w/Seat Depth Adj, Height/Adjustable Arms	\$466.65	\$466.65
					
			OPTIONS		
			CH1 Standard Cylinder (Cylinder Height Option)		
			FC1 Black Frame (Frame Color Selection)		
			BT2 5 Star Polished Aluminum Base(For Any Frame Color) (Base Selection)		
			CS6 Hard Floor And Carpet Casters (Caster Selection)		
			MC21 Nickel Mesh (Hexy Mesh Back Colors)		
			US Upholstered Seat (Hexy Upholstered Seat Material Selection)		
			FG2 Fabric/Vinyl Grade 2 (Fabric Grade Selections)		
			ELEMENT Element Color Selection (Fabric Grade 2 Selection)		
			CHARCOAL Element Charcoal (Element Color Selection)		
			UC Back Attached To Seat, Base Separate (Packaging Options)		
2	1.00	EA	1191SW19S2.US.UB.AR0 / Cora 30" Bar Stool, Armless	\$299.70	\$299.70
					
			OPTIONS		
			FC2 Silver Frame (Frame Information)		
			GL2 Performance Multi-Surface Glides (Caster/Glide Option Selection)		
			~ No Moisture Barrier (Moisture Barrier)		
			USU Single Upholstered (Fabric Option)		
			~ No Ballistic Nylon Option (Ballistic Nylon Option Selection)		
			FG2 Fabric/Vinyl Grade 2 (CORA Single Upholstered)		
			ELEMENT Element Color Selection (Fabric Grade 2 Selection)		
			CHARCOAL Element Charcoal (Element Color Selection)		
			AC Fully Assembled In Carton (Packaging Options)		
3	1.00	EA	INTDLR2460 / Instruct Teacher Pedestal Desk,D-Shape Top,T-Leg,Laminate Mod. Panel,BBF Ped Right,24Dx60Wx29H,74P edge	\$913.14	\$913.14
			OPTIONS		
			/USP Nickel Arc (Pull Option)		
			LAMG1 Laminate Grade 1 (Laminate)		
			LAMGRD1STD Grade 1 Ki Standard Laminates (Laminate Finish)		
			/LDR Designer White D354-60 (Grade 1 KI standard laminates)		
			/EDR Designer White Edge (Edge Color)		
			/SX Starlight Silver Metallic (Paint Color)		
			/KA Key Alike (Lock Option)		
			/SCL Satin Chrome (Lock Color)		

Transylvania County Schools TC Henderson Elementary

Teacher

LINE #	QTY	UNIT	PART # / DESCRIPTION	PRICE EA	EXT PRICE
4	1.00	EA	ATMTDP2466-74P-WSL-S3 / All Terrain Mobile Instructors Desk,Steel Door,Aluminum Bow Tie Pull,Left Worksurface,66"	\$1,839.96	\$1,839.96
					
OPTIONS					
LAMG1 Laminate Grade 1 (Laminate)					
LAMGRD1STD Grade 1 Ki Standard Laminates (Laminate Finish)					
/LDR Designer White D354-60 (Grade 1 Ki standard laminates)					
/SX Starlight Silver Metallic (Unit Color)					
/KA Key Alike (Lock Option)					
/SCL Satin Chrome (Lock Color)					
/L107 Key Alike Lock #107 (National Key Alike)					
/EDR Designer White Edge (Edge Color)					

Classroom

LINE #	QTY	UNIT	PART # / DESCRIPTION	PRICE EA	EXT PRICE
5	30.00	EA	IW415 / Intellect Wave 4-Leg Chair,Medium,15"H	\$105.45	\$3,163.50
					
OPTIONS					
/NG Nylon Glides (Glide Option)					
/CTN Cartoned (Carton Code Option)					
/CH Chrome (Intellect Wave Frame Color)					
/NFR No Fire Retardant (Shell Color)					
/PBL Black (Shell NFR)					
6	30.00	EA	IWD4FL/A / Intellect Wave 4-Leg Desk,Adj Height,Laminate Top,Ships Assembled,Curved Front	\$257.07	\$7,712.10
					
OPTIONS					
/SBBH Steel Book Box And Bag Hooks (Book Storage Option)					
/SBL Black (Steel Book Box Color)					
/BL Black (Intellect Wave Frame Color)					
/ECO Castle Oak Edge (Edge Finish)					
LAMG1 Laminate Grade 1 (Laminate)					
LAMGRD1STD Grade 1 Ki Standard Laminates (Laminate Finish)					
/LCO Castle Oak 7928-38 (Grade 1 Ki standard laminates)					
/NG Nylon Glides (Glide Option)					
INFO Top Size 19"X26" (Top Size)					
INFO Height Range 22-34" (Height Range)					
7	1.00	EA	Furniture Labor / Installation / Labor to receive, deliver and install during normal business hours.	\$894.00	\$894.00

PBI, Inc. **Attachment A**
123 Sweeten Creek Rd, Suite A
Asheville, NC 28803
Phone: (828) 277-7001
Fax: (828) 277-7003
pbiasheville.com



QUOTATION

1259-25919

VALID UNTIL 3/27/2026

Transylvania County Schools TC Henderson Elementary

CUSTOMER SIGN OFF

subtotal	\$15,289.05
sales tax	\$1,032.02
total	\$16,321.07

Authorized Signature

Accepted Date

Print Name



PBI Terms and Conditions

Disclaimer:

-PO and/or Signature along with materials deposit required to process order. We appreciate this opportunity and look forward to a successful project!

-All prices are based on information discussed. Budgets can vary based on the final selections of materials and accessories. PBI's services are figured for normal business hours unless discussed otherwise. PBI has included all known elements within this good faith estimate. If unknown issues arise, they will be discussed with the team to determine best plan of action to proceed.

-PBI orders are specific to each client/project. Any orders changed or cancelled after order processing will result in change fees, full materials charge, or applicable restocking fees.

-75% deposit required unless client has been approved for credit terms

-PBI to invoice based on progress of job which will include materials delivered to site and/or stored materials in PBI warehouse.

-Storage Fee of \$350 per week will be charged on goods held over 30 days unless arrangements have been made.

-PBI accepts credit card transactions with a 4% transaction fee.

-PBI, Inc reserves the right to raise the material price on this proposal by the percentage increase of any publicly announced tariff that may take place before this proposal is accepted by the (customer/client). If PBI, Inc is awarded the contract, any price increase of material due to tariffs during the performance of the contract through no fault of the Contractor, the contract sum shall be equitably adjusted by change order in accordance with the procedures of the contract documents. A change in price of an item of material shall be considered significant when the price of an item increases 10% or more between the date of the contract and the date of installation.

-Phased installations, trips, and material deliveries to be determined prior to signed proposal. Any additions or changes will result in additional charges. Job sites must have clear and safe access for delivery.

Additional Terms for Flooring-Construction- Windows and Doors

-Any unforeseen circumstances will be discussed with the owner/project manager and additional charges may apply.

- Flooring installation requires-All HVAC and Lighting to be in operation prior to installation. PBI excludes the following unless otherwise noted in proposal: Floor Leveling; Moisture Mitigation; Nights/Weekends; Floor Protection; Expansion Joints; Dumpsters.

-PBI cannot accept responsibility for costs that may be associated with delays and product production and delivery to job site.

-All products delivered to jobsite must be inspected at time of delivery and will require signature. PBI will only accept responsibility for noted missing or damaged items.

PBI, Inc. **Attachment A**
 123 Sweeten Creek Rd, Suite A
 Asheville, NC 28803
 Phone: (828) 277-7001
 Fax: (828) 277-7003
 pbiasheville.com



DEPOSIT INVOICE

1259-25919-0

Due Upon Receipt
 2/25/2026

Bill To

Kerry Putnam
 Transylvania County Schools
 225 Rosenwald Lane
 Brevard, NC 28712

Install To / End User

Packy Chapman
 Transylvania County Schools
 T C Henderson Elementary School
 11839 Rosman Hwy
 Lake Toxaway, NC 28747

PROJECT #	SALESPERSON	QUOTE NAME	PROJECT NAME
1259	Michelle Stevenson	New Option	Transylvania County Schools TC Henderson Elementary

Deposit Details Summarized by Phase

Option	Phase	Price	Tax	Total	Deposit Amount
Transylvania County Schools TC Henderson Elementary	Teacher	\$3,519.45	\$237.56	\$3,757.01	\$2,817.76
	Classroom	\$11,769.60	\$794.46	\$12,564.06	\$9,423.05
Total		\$15,289.05	\$1,032.02	\$16,321.07	\$12,240.80

Order Total	\$15,289.05
Sales Tax	\$1,032.02
Total	\$16,321.07
75% Deposit Due	\$12,240.80



Transylvania County Schools

PRICE PROPOSAL

Date: 2/26/2026

Prepared For: Jessica McCall

Quote Number: 1244-25906

Valid For 29 Days

Prepared by: Michelle Stevenson

Confidential

© 2026 PBI, Inc..The information in this transmittal is proprietary to PBI, Inc.. It is provided on the condition that it remains in confidence between PBI, Inc. and the recipient of this quote. Do Not Copy, Distribute nor Share the Contents of this proposal without the written permission of PBI, Inc..



Project Scope

Bill To

Kerry Putnam
 Transylvania County Schools
 225 Rosenwald Lane
 Brevard, NC 28712

Install To

Jessica McCall
 Transylvania County Schools
 Brevard Middle School
 400 Fisher Rd
 Brevard, NC 28712

Project Investment

Project Total	\$14,311.65
Tax (6.75%)	\$966.04
Grand Total	\$15,277.69

Payment Schedule

75% Deposit / Net 30 Days

75% Deposit / Net 30 Days	\$11,458.27
---------------------------	-------------

Price Summary by Phase

Option	Phase / TAG	Price	Tax	Total
Transylvania County Schools- Brevard Middle Furniture Full Classroom	Teacher	\$3,519.45	\$237.56	\$3,757.01
	Classroom	\$6,720.30	\$453.62	\$7,173.92
	Chairs	\$4,071.90	\$274.85	\$4,346.75
		\$14,311.65	\$966.04	\$15,277.69
Grand Total		\$14,311.65	\$966.04	\$15,277.69

BILL TO

Kerry Putnam
 Transylvania County Schools
 225 Rosenwald Lane
 Brevard, NC 28712

INSTALL TO

Jessica McCall
 Transylvania County Schools
 Brevard Middle School
 400 Fisher Rd
 Brevard, NC 28712

Salesperson
 Michelle Stevenson

Payment Terms
 75% Deposit / Net 30 Days



SHIP TO

Jessica McCall
 Transylvania County Schools
 Brevard Middle School
 400 Fisher Rd
 Brevard, NC 28712

All Pricing per KI on NC State Contract. Shipping from factory included.

Transylvania County Schools- Brevard Middle Furniture Full Classroom

Teacher

LINE #	QTY	UNIT	PART # / DESCRIPTION	PRICE EA	EXT PRICE
1	1.00	EA	1203.BK2.MB.FE3.AR4 / Hexy, Highback, Mesh Back, Standard Synchro w/Seat Depth Adj, Height/Adjustable Arms	\$466.65	\$466.65
			 OPTIONS		
			CH1 Standard Cylinder (Cylinder Height Option)		
			FC1 Black Frame (Frame Color Selection)		
			BT2 5 Star Polished Aluminum Base(For Any Frame Color) (Base Selection)		
			CS6 Hard Floor And Carpet Casters (Caster Selection)		
			MC21 Nickel Mesh (Hexy Mesh Back Colors)		
			US Upholstered Seat (Hexy Upholstered Seat Material Selection)		
			FG2 Fabric/Vinyl Grade 2 (Fabric Grade Selections)		
			ELEMENT Element Color Selection (Fabric Grade 2 Selection)		
			CHARCOAL Element Charcoal (Element Color Selection)		
			UC Back Attached To Seat, Base Separate (Packaging Options)		
2	1.00	EA	1191SW19S2.US.UB.AR0 / Cora 30" Bar Stool, Armless	\$299.70	\$299.70
			 OPTIONS		
			FC2 Silver Frame (Frame Information)		
			GL2 Performance Multi-Surface Glides (Caster/Glide Option Selection)		
			~ No Moisture Barrier (Moisture Barrier)		
			USU Single Upholstered (Fabric Option)		
			~ No Ballistic Nylon Option (Ballistic Nylon Option Selection)		
			FG2 Fabric/Vinyl Grade 2 (CORA Single Upholstered)		
			ELEMENT Element Color Selection (Fabric Grade 2 Selection)		
			CHARCOAL Element Charcoal (Element Color Selection)		
			AC Fully Assembled In Carton (Packaging Options)		
3	1.00	EA	INTDLR2460 / Instruct Teacher Pedestal Desk,D-Shape Top,T-Leg,Laminate Mod. Panel,BBF Ped Right,24Dx60Wx29H,74P edge	\$913.14	\$913.14
			OPTIONS		
			/USP Nickel Arc (Pull Option)		
			LAMG1 Laminate Grade 1 (Laminate)		
			LAMGRD1STD Grade 1 Ki Standard Laminates (Laminate Finish)		
			/LDR Designer White D354-60 (Grade 1 KI standard laminates)		
			/EDR Designer White Edge (Edge Color)		
			/SX Starlight Silver Metallic (Paint Color)		
			/KA Key Alike (Lock Option)		
			/SCL Satin Chrome (Lock Color)		

Transylvania County Schools- Brevard Middle Furniture Full Classroom

Teacher

LINE #	QTY	UNIT	PART # / DESCRIPTION	PRICE EA	EXT PRICE
4	1.00	EA	ATMTDP2466-74P-WSL-S3 / All Terrain Mobile Instructors Desk,Steel Door,Aluminum Bow Tie Pull,Left Worksurface,66"	\$1,839.96	\$1,839.96
					
OPTIONS					
LAMG1 Laminate Grade 1 (Laminate)					
LAMGRD1STD Grade 1 Ki Standard Laminates (Laminate Finish)					
/LDR Designer White D354-60 (Grade 1 Ki standard laminates)					
/SX Starlight Silver Metallic (Unit Color)					
/KA Key Alike (Lock Option)					
/SCL Satin Chrome (Lock Color)					
/L107 Key Alike Lock #107 (National Key Alike)					
/EDR Designer White Edge (Edge Color)					

Classroom

LINE #	QTY	UNIT	PART # / DESCRIPTION	PRICE EA	EXT PRICE
5	30.00	EA	IWD4FH/A / Intellect Wave 4-Leg Desk,Adj Height,Hard Plastic Top,Ships Assembled	\$224.01	\$6,720.30
					
OPTIONS					
/BH Bag Hooks (Book Storage Option)					
/BL Black (Intellect Wave Frame Color)					
/LWL White Nebula (Plastic Top Surface Color)					
/SF Felt Solo Glide (Glide Option)					
/SFT Straight Front Top (Top Shape)					
INFO Top Size 19-3/8"X26-3/4" (Top Size)					
INFO Height Range 22-34" (Height Range)					

Chairs

LINE #	QTY	UNIT	PART # / DESCRIPTION	PRICE EA	EXT PRICE
6	30.00	EA	IW418 / Intellect Wave 4-Leg Chair, Large, 18"H	\$107.73	\$3,231.90
					
OPTIONS					
/SF Felt Solo Glide (Glide Option)					
/RCK Racked (Carton Code Option)					
/CH Chrome (Intellect Wave Frame Color)					
/NFR No Fire Retardant (Shell Color)					
/PND Nordic (Shell NFR)					
7	1.00	EA	Furniture Labor / Installation / Labor to receive and deliver classroom furniture for 30 students and teach. Room location TBD	\$840.00	\$840.00

PBI, Inc. **Attachment A**
123 Sweeten Creek Rd, Suite A
Asheville, NC 28803
Phone: (828) 277-7001
Fax: (828) 277-7003
pbiasheville.com



QUOTATION

1244-25906

VALID UNTIL 3/27/2026

Transylvania County Schools- Brevard Middle Furniture Full Classroom

CUSTOMER SIGN OFF

subtotal	\$14,311.65
sales tax	\$966.04
total	\$15,277.69

Authorized Signature

Accepted Date

Print Name



PBI Terms and Conditions

Disclaimer:

-PO and/or Signature along with materials deposit required to process order. We appreciate this opportunity and look forward to a successful project!

-All prices are based on information discussed. Budgets can vary based on the final selections of materials and accessories. PBI's services are figured for normal business hours unless discussed otherwise. PBI has included all known elements within this good faith estimate. If unknown issues arise, they will be discussed with the team to determine best plan of action to proceed.

-PBI orders are specific to each client/project. Any orders changed or cancelled after order processing will result in change fees, full materials charge, or applicable restocking fees.

-75% deposit required unless client has been approved for credit terms

-PBI to invoice based on progress of job which will include materials delivered to site and/or stored materials in PBI warehouse.

-Storage Fee of \$350 per week will be charged on goods held over 30 days unless arrangements have been made.

-PBI accepts credit card transactions with a 4% transaction fee.

-PBI, Inc reserves the right to raise the material price on this proposal by the percentage increase of any publicly announced tariff that may take place before this proposal is accepted by the (customer/client). If PBI, Inc is awarded the contract, any price increase of material due to tariffs during the performance of the contract through no fault of the Contractor, the contract sum shall be equitably adjusted by change order in accordance with the procedures of the contract documents. A change in price of an item of material shall be considered significant when the price of an item increases 10% or more between the date of the contract and the date of installation.

-Phased installations, trips, and material deliveries to be determined prior to signed proposal. Any additions or changes will result in additional charges. Job sites must have clear and safe access for delivery.

Additional Terms for Flooring-Construction- Windows and Doors

-Any unforeseen circumstances will be discussed with the owner/project manager and additional charges may apply.

- Flooring installation requires-All HVAC and Lighting to be in operation prior to installation. PBI excludes the following unless otherwise noted in proposal: Floor Leveling; Moisture Mitigation; Nights/Weekends; Floor Protection; Expansion Joints; Dumpsters.

-PBI cannot accept responsibility for costs that may be associated with delays and product production and delivery to job site.

-All products delivered to jobsite must be inspected at time of delivery and will require signature. PBI will only accept responsibility for noted missing or damaged items.

PBI, Inc. **Attachment A**
 123 Sweeten Creek Rd, Suite A
 Asheville, NC 28803
 Phone: (828) 277-7001
 Fax: (828) 277-7003
 pbiasheville.com



DEPOSIT INVOICE

1244-25906-0

Due Upon Receipt
 2/26/2026

Bill To Kerry Putnam Transylvania County Schools 225 Rosenwald Lane Brevard, NC 28712	Ship To Jessica McCall Transylvania County Schools Brevard Middle School 400 Fisher Rd Brevard, NC 28712	Install To / End User Jessica McCall Transylvania County Schools Brevard Middle School 400 Fisher Rd Brevard, NC 28712
--	--	--

PROJECT #	SALESPERSON	QUOTE NAME	PROJECT NAME
1244	Michelle Stevenson	Transylvania County Schools- Brevard Middle	Classroom Furniture

Deposit Details Summarized by Phase

Option	Phase	Price	Tax	Total	Deposit Amount
Transylvania County Schools- Brevard Middle Furniture Full Classroom	Teacher	\$3,519.45	\$237.56	\$3,757.01	\$2,817.76
	Classroom	\$6,720.30	\$453.62	\$7,173.92	\$5,380.44
	Chairs	\$4,071.90	\$274.85	\$4,346.75	\$3,260.06
Total		\$14,311.65	\$966.04	\$15,277.69	\$11,458.26

Order Total	\$14,311.65
Sales Tax	\$966.04
Total	\$15,277.69
<hr/>	
75% Deposit Due	\$11,458.26



Transylvania County Schools

PRICE PROPOSAL

Date: 2/26/2026

Prepared For: Julie Queen

Quote Number: 1245-25907

Valid For 29 Days

Prepared by: Michelle Stevenson

Confidential

© 2026 PBI, Inc..The information in this transmittal is proprietary to PBI, Inc.. It is provided on the condition that it remains in confidence between PBI, Inc. and the recipient of this quote. Do Not Copy, Distribute nor Share the Contents of this proposal without the written permission of PBI, Inc..



Project Scope

Bill To

Kerry Putnam
 Transylvania County Schools
 225 Rosenwald Lane
 Brevard, NC 28712

Project Investment

Project Total	\$15,013.85
Tax (6.75%)	\$1,013.44
Grand Total	\$16,027.29

Install To

Julie Queen
 Transylvania County Schools
 Rosman Middle School
 2770 Old Rosman Hwy,
 Rosman, NC 28772

Payment Schedule

75% Deposit / Net 30 Days

75% Deposit / Net 30 Days	\$12,020.46
---------------------------	-------------

Price Summary by Phase

Option	Phase / TAG	Price	Tax	Total
Transylvania County Schools Rosman Middle Furniture Full Classroom	Teacher	\$3,519.45	\$237.56	\$3,757.01
	Middle School Grade Classroom	\$11,494.40	\$775.87	\$12,270.27
		\$15,013.85	\$1,013.44	\$16,027.29
Grand Total		\$15,013.85	\$1,013.44	\$16,027.29

BILL TO

Kerry Putnam
 Transylvania County Schools
 225 Rosenwald Lane
 Brevard, NC 28712

INSTALL TO

Julie Queen
 Transylvania County Schools
 Rosman Middle School
 2770 Old Rosman Hwy,
 Rosman, NC 28772



Salesperson
 Michelle Stevenson

Payment Terms
 75% Deposit / Net 30 Days

All KI pricing per NC State Contract. Shipping from factory included.

Transylvania County Schools Rosman Middle Furniture Full Classroom

Teacher



LINE #	QTY	UNIT	PART # / DESCRIPTION	PRICE EA	EXT PRICE
1	1.00	EA	1203.BK2.MB.FE3.AR4 / Hexy, Highback, Mesh Back, Standard Synchro w/Seat Depth Adj, Height/Adjustable Arms	\$466.65	\$466.65
			 OPTIONS CH1 Standard Cylinder (Cylinder Height Option) FC1 Black Frame (Frame Color Selection) BT2 5 Star Polished Aluminum Base(For Any Frame Color) (Base Selection) CS6 Hard Floor And Carpet Casters (Caster Selection) MC21 Nickel Mesh (Hexy Mesh Back Colors) US Upholstered Seat (Hexy Upholstered Seat Material Selection) FG2 Fabric/Vinyl Grade 2 (Fabric Grade Selections) ELEMENT Element Color Selection (Fabric Grade 2 Selection) CHARCOAL Element Charcoal (Element Color Selection) UC Back Attached To Seat, Base Separate (Packaging Options)		
2	1.00	EA	1191SW19S2.US.UB.AR0 / Cora 30" Bar Stool, Armless	\$299.70	\$299.70
			 OPTIONS FC2 Silver Frame (Frame Information) GL2 Performance Multi-Surface Glides (Caster/Glide Option Selection) ~ No Moisture Barrier (Moisture Barrier) USU Single Upholstered (Fabric Option) ~ No Ballistic Nylon Option (Ballistic Nylon Option Selection) FG2 Fabric/Vinyl Grade 2 (CORA Single Upholstered) ELEMENT Element Color Selection (Fabric Grade 2 Selection) CHARCOAL Element Charcoal (Element Color Selection) AC Fully Assembled In Carton (Packaging Options)		
3	1.00	EA	INTDLR2460 / Instruct Teacher Pedestal Desk,D-Shape Top,T-Leg,Laminate Mod. Panel,BBF Ped Right,24Dx60Wx29H,74P edge	\$913.14	\$913.14
			OPTIONS /USP Nickel Arc (Pull Option) LAMG1 Laminate Grade 1 (Laminate) LAMGRD1STD Grade 1 Ki Standard Laminates (Laminate Finish) /LDR Designer White D354-60 (Grade 1 Ki standard laminates) /EDR Designer White Edge (Edge Color) /SX Starlight Silver Metallic (Paint Color) /KA Key Alike (Lock Option) /SCL Satin Chrome (Lock Color)		

Transylvania County Schools Rosman Middle Furniture Full Classroom

Teacher

LINE #	QTY	UNIT	PART # / DESCRIPTION	PRICE EA	EXT PRICE
4	1.00	EA	ATMTDP2466-74P-WSL-S3 / All Terrain Mobile Instructors Desk,Steel Door,Aluminum Bow Tie Pull,Left Worksurface,66"	\$1,839.96	\$1,839.96
 <p>OPTIONS</p> <p>LAMG1 Laminate Grade 1 (Laminate) LAMGRD1STD Grade 1 Ki Standard Laminates (Laminate Finish) /LDR Designer White D354-60 (Grade 1 KI standard laminates) /SX Starlight Silver Metallic (Unit Color) /KA Key Alike (Lock Option) /SCL Satin Chrome (Lock Color) /L107 Key Alike Lock #107 (National Key Alike) /EDR Designer White Edge (Edge Color)</p>					

Middle School Grade Classroom

LINE #	QTY	UNIT	PART # / DESCRIPTION	PRICE EA	EXT PRICE
5	29.00	EA	RDEEA2030-73P / Ruckus,Fixed Height Post-Leg Desk 28-1/2",Rectangle,3/4"Top,73P Edge,20x30"	\$229.14	\$6,645.06
 <p>OPTIONS</p> <p>/EKM Kensington Maple Edge (Edge Color) LAMG1 Laminate Grade 1 (Laminate) LAMGRD1STD Grade 1 Ki Standard Laminates (Laminate Finish) /LKM Kensington Maple 10776-60 (Grade 1 KI standard laminates) /FN Flannel (Base Finish) /GNY Nylon Glides (Caster/Glides) /NB No Book Storage (Under Table Storage)</p>					
6	1.00	EA	RDEEA2030-73P / Ruckus,Sit Height Adjustable Post-Leg Desk 19-1/2 to 32-1/2",Rectangle,3/4"Top,73P Edge,20x30"	\$257.64	\$257.64
 <p>OPTIONS</p> <p>/EKM Kensington Maple Edge (Edge Color) LAMG1 Laminate Grade 1 (Laminate) LAMGRD1STD Grade 1 Ki Standard Laminates (Laminate Finish) /LKM Kensington Maple 10776-60 (Grade 1 KI standard laminates) /FN Flannel (Base Finish) /GNY Nylon Glides (Caster/Glides) /NB No Book Storage (Under Table Storage)</p>					
7	30.00	EA	RKUSBBH1 / Ruckus,Book Bag Hook Kit,Chrome	\$5.70	\$171.00
8	30.00	EA	CGG100H16 / Cogni Cantilever Chair, Glide Base, Poly, Medium 16"H	\$117.99	\$3,539.70
 <p>OPTIONS</p> <p>/FN Flannel (Frame Color) /PFN Flannel (Shell Color) /GHY Hybrid Glide (Glide Option) /BBL Black (Glide/Wheel Color) /CTN Cartoned (Packaging Option)</p>					
9	1.00	EA	Furniture Labor / Installation / Labor to receive, deliver and install during normal business hours.	\$881.00	\$881.00

PBI, Inc. **Attachment A**
123 Sweeten Creek Rd, Suite A
Asheville, NC 28803
Phone: (828) 277-7001
Fax: (828) 277-7003
pbiasheville.com



QUOTATION

1245-25907

VALID UNTIL 3/27/2026

Transylvania County Schools Rosman Middle Furniture Full Classroom

CUSTOMER SIGN OFF

subtotal	\$15,013.85
sales tax	\$1,013.44
total	\$16,027.29

Authorized Signature

Accepted Date

Print Name



PBI Terms and Conditions

Disclaimer:

-PO and/or Signature along with materials deposit required to process order. We appreciate this opportunity and look forward to a successful project!

-All prices are based on information discussed. Budgets can vary based on the final selections of materials and accessories. PBI's services are figured for normal business hours unless discussed otherwise. PBI has included all known elements within this good faith estimate. If unknown issues arise, they will be discussed with the team to determine best plan of action to proceed.

-PBI orders are specific to each client/project. Any orders changed or cancelled after order processing will result in change fees, full materials charge, or applicable restocking fees.

-75% deposit required unless client has been approved for credit terms

-PBI to invoice based on progress of job which will include materials delivered to site and/or stored materials in PBI warehouse.

-Storage Fee of \$350 per week will be charged on goods held over 30 days unless arrangements have been made.

-PBI accepts credit card transactions with a 4% transaction fee.

-PBI, Inc reserves the right to raise the material price on this proposal by the percentage increase of any publicly announced tariff that may take place before this proposal is accepted by the (customer/client). If PBI, Inc is awarded the contract, any price increase of material due to tariffs during the performance of the contract through no fault of the Contractor, the contract sum shall be equitably adjusted by change order in accordance with the procedures of the contract documents. A change in price of an item of material shall be considered significant when the price of an item increases 10% or more between the date of the contract and the date of installation.

-Phased installations, trips, and material deliveries to be determined prior to signed proposal. Any additions or changes will result in additional charges. Job sites must have clear and safe access for delivery.

Additional Terms for Flooring-Construction- Windows and Doors

-Any unforeseen circumstances will be discussed with the owner/project manager and additional charges may apply.

- Flooring installation requires-All HVAC and Lighting to be in operation prior to installation. PBI excludes the following unless otherwise noted in proposal: Floor Leveling; Moisture Mitigation; Nights/Weekends; Floor Protection; Expansion Joints; Dumpsters.

-PBI cannot accept responsibility for costs that may be associated with delays and product production and delivery to job site.

-All products delivered to jobsite must be inspected at time of delivery and will require signature. PBI will only accept responsibility for noted missing or damaged items.

PBI, Inc. **Attachment A**
 123 Sweeten Creek Rd, Suite A
 Asheville, NC 28803
 Phone: (828) 277-7001
 Fax: (828) 277-7003
 pbiasheville.com



DEPOSIT INVOICE

1245-25907-0

Due Upon Receipt
 2/26/2026

Bill To

Kerry Putnam
 Transylvania County Schools
 225 Rosenwald Lane
 Brevard, NC 28712

Install To / End User

Julie Queen
 Transylvania County Schools
 Rosman Middle School
 2770 Old Rosman Hwy,
 Rosman, NC 28772

PROJECT #	SALESPERSON	QUOTE NAME	PROJECT NAME
1245	Michelle Stevenson	Transylvania County Schools Rosman Middle Furniture	Transylvania County Schools Rosman Middle Furniture Full Classroom

Deposit Details Summarized by Phase

Option	Phase	Price	Tax	Total	Deposit Amount
Transylvania County Schools Rosman Middle Furniture Full Classroom	Teacher	\$3,519.45	\$237.56	\$3,757.01	\$2,817.76
	Middle School Grade Classroom	\$11,494.40	\$775.87	\$12,270.27	\$9,202.70
Total		\$15,013.85	\$1,013.44	\$16,027.29	\$12,020.46

Order Total	\$15,013.85
Sales Tax	\$1,013.44
Total	\$16,027.29
75% Deposit Due	\$12,020.46



Transylvania County Schools

PRICE PROPOSAL

Date: 2/26/2026

Quote Number: 1266-25925

Valid For 30 Days

Prepared by: Michelle Stevenson

Confidential

© 2026 PBI, Inc..The information in this transmittal is proprietary to PBI, Inc.. It is provided on the condition that it remains in confidence between PBI, Inc. and the recipient of this quote. Do Not Copy, Distribute nor Share the Contents of this proposal without the written permission of PBI, Inc..



Project Scope

Bill To

Kerry Putnam
 Transylvania County Schools
 225 Rosenwald Lane
 Brevard, NC 28712

Project Investment

Project Total	\$14,311.65
Tax (6.75%)	\$966.04
Grand Total	\$15,277.69

Install To

Transylvania County Schools
 Davidson River School
 970 Ecusta Rd
 Brevard, NC 28712

Payment Schedule

75% Deposit / Net 30 Days

75% Deposit / Net 30 Days	\$11,458.27
---------------------------	-------------

Price Summary by Phase

Option	Phase / TAG	Price	Tax	Total
Transylvania County Schools Davidson River Classroom Furniture	Teacher	\$3,519.45	\$237.56	\$3,757.01
	Classroom	\$6,720.30	\$453.62	\$7,173.92
	CHAIRS	\$4,071.90	\$274.85	\$4,346.75
		\$14,311.65	\$966.04	\$15,277.69
Grand Total		\$14,311.65	\$966.04	\$15,277.69



BILL TO
 Kerry Putnam
 Transylvania County Schools
 225 Rosenwald Lane
 Brevard, NC 28712

INSTALL TO
 Transylvania County Schools
 Davidson River School
 970 Ecusta Rd
 Brevard, NC 28712



Salesperson
 Michelle Stevenson

Payment Terms
 75% Deposit / Net 30 Days

All Sit On It and KI pricing per NC State Contract. Factory shipping included.

Transylvania County Schools Davidson River Classroom Furniture

Teacher

LINE #	QTY	UNIT	PART # / DESCRIPTION	PRICE EA	EXT PRICE
1	1.00	EA	1203.BK2.MB.FE3.AR4 / Hexy, Highback, Mesh Back, Standard Synchro w/Seat Depth Adj, Height/Adjustable Arms	\$466.65	\$466.65
			 OPTIONS CH1 Standard Cylinder (Cylinder Height Option) FC1 Black Frame (Frame Color Selection) BT2 5 Star Polished Aluminum Base(For Any Frame Color) (Base Selection) CS6 Hard Floor And Carpet Casters (Caster Selection) MC21 Nickel Mesh (Hexy Mesh Back Colors) US Upholstered Seat (Hexy Upholstered Seat Material Selection) FG2 Fabric/Vinyl Grade 2 (Fabric Grade Selections) ELEMENT Element Color Selection (Fabric Grade 2 Selection) CHARCOAL Element Charcoal (Element Color Selection) UC Back Attached To Seat, Base Separate (Packaging Options)		
2	1.00	EA	1191SW19S2.US.UB.ARO / Cora 30" Bar Stool, Armless	\$299.70	\$299.70
			 OPTIONS FC2 Silver Frame (Frame Information) GL2 Performance Multi-Surface Glides (Caster/Glide Option Selection) ~ No Moisture Barrier (Moisture Barrier) USU Single Upholstered (Fabric Option) ~ No Ballistic Nylon Option (Ballistic Nylon Option Selection) FG2 Fabric/Vinyl Grade 2 (CORA Single Upholstered) ELEMENT Element Color Selection (Fabric Grade 2 Selection) CHARCOAL Element Charcoal (Element Color Selection) AC Fully Assembled In Carton (Packaging Options)		
3	1.00	EA	INTDLR2460 / Instruct Teacher Pedestal Desk,D-Shape Top,T-Leg,Laminate Mod. Panel,BBF Ped Right,24Dx60Wx29H,74P edge	\$913.14	\$913.14
			OPTIONS /USP Nickel Arc (Pull Option) LAMG1 Laminate Grade 1 (Laminate) LAMGRD1STD Grade 1 Ki Standard Laminates (Laminate Finish) /LDR Designer White D354-60 (Grade 1 Ki standard laminates) /EDR Designer White Edge (Edge Color) /SX Starlight Silver Metallic (Paint Color) /KA Key Alike (Lock Option) /SCL Satin Chrome (Lock Color)		

Transylvania County Schools Davidson River Classroom Furniture

Teacher

LINE #	QTY	UNIT	PART # / DESCRIPTION	PRICE EA	EXT PRICE
4	1.00	EA	ATMTDP2466-74P-WSL-S3 / All Terrain Mobile Instructors Desk,Steel Door,Aluminum Bow Tie Pull,Left Worksurface,66"	\$1,839.96	\$1,839.96
					
OPTIONS LAMG1 Laminate Grade 1 (Laminate) LAMGRD1STD Grade 1 Ki Standard Laminates (Laminate Finish) /LDR Designer White D354-60 (Grade 1 Ki standard laminates) /SX Starlight Silver Metallic (Unit Color) /KA Key Alike (Lock Option) /SCL Satin Chrome (Lock Color) /L107 Key Alike Lock #107 (National Key Alike) /EDR Designer White Edge (Edge Color)					

Classroom

LINE #	QTY	UNIT	PART # / DESCRIPTION	PRICE EA	EXT PRICE
5	30.00	EA	IWD4FH/A / Intellect Wave 4-Leg Desk,Adj Height,Hard Plastic Top,Ships Assembled	\$224.01	\$6,720.30
					
OPTIONS /BH Bag Hooks (Book Storage Option) /BL Black (Intellect Wave Frame Color) /LWL White Nebula (Plastic Top Surface Color) /SF Felt Solo Glide (Glide Option) /SFT Straight Front Top (Top Shape) INFO Top Size 19-3/8"X26-3/4" (Top Size) INFO Height Range 22-34" (Height Range)					

CHAIRS

LINE #	QTY	UNIT	PART # / DESCRIPTION	PRICE EA	EXT PRICE
6	30.00	EA	IW418 / Intellect Wave 4-Leg Chair, Large, 18"H	\$107.73	\$3,231.90
					
OPTIONS /SF Felt Solo Glide (Glide Option) /RCK Racked (Carton Code Option) /CH Chrome (Intellect Wave Frame Color) /NFR No Fire Retardant (Shell Color) /PND Nordic (Shell NFR)					
7	1.00	EA	Furniture Labor / Installation / Labor to receive and deliver classroom furniture for 30 students and teach. Room location TBD	\$840.00	\$840.00

PBI, Inc. **Attachment A**
123 Sweeten Creek Rd, Suite A
Asheville, NC 28803
Phone: (828) 277-7001
Fax: (828) 277-7003
pbiasheville.com



QUOTATION

1266-25925

VALID UNTIL 3/28/2026

Transylvania County Schools Davidson River Classroom Furniture

CUSTOMER SIGN OFF

subtotal	\$14,311.65
sales tax	\$966.04
total	\$15,277.69

Authorized Signature

Accepted Date

Print Name



PBI Terms and Conditions

Disclaimer:

-PO and/or Signature along with materials deposit required to process order. We appreciate this opportunity and look forward to a successful project!

-All prices are based on information discussed. Budgets can vary based on the final selections of materials and accessories. PBI's services are figured for normal business hours unless discussed otherwise. PBI has included all known elements within this good faith estimate. If unknown issues arise, they will be discussed with the team to determine best plan of action to proceed.

-PBI orders are specific to each client/project. Any orders changed or cancelled after order processing will result in change fees, full materials charge, or applicable restocking fees.

-75% deposit required unless client has been approved for credit terms

-PBI to invoice based on progress of job which will include materials delivered to site and/or stored materials in PBI warehouse.

-Storage Fee of \$350 per week will be charged on goods held over 30 days unless arrangements have been made.

-PBI accepts credit card transactions with a 4% transaction fee.

-PBI, Inc reserves the right to raise the material price on this proposal by the percentage increase of any publicly announced tariff that may take place before this proposal is accepted by the (customer/client). If PBI, Inc is awarded the contract, any price increase of material due to tariffs during the performance of the contract through no fault of the Contractor, the contract sum shall be equitably adjusted by change order in accordance with the procedures of the contract documents. A change in price of an item of material shall be considered significant when the price of an item increases 10% or more between the date of the contract and the date of installation.

-Phased installations, trips, and material deliveries to be determined prior to signed proposal. Any additions or changes will result in additional charges. Job sites must have clear and safe access for delivery.

Additional Terms for Flooring-Construction- Windows and Doors

-Any unforeseen circumstances will be discussed with the owner/project manager and additional charges may apply.

- Flooring installation requires-All HVAC and Lighting to be in operation prior to installation. PBI excludes the following unless otherwise noted in proposal: Floor Leveling; Moisture Mitigation; Nights/Weekends; Floor Protection; Expansion Joints; Dumpsters.

-PBI cannot accept responsibility for costs that may be associated with delays and product production and delivery to job site.

-All products delivered to jobsite must be inspected at time of delivery and will require signature. PBI will only accept responsibility for noted missing or damaged items.

PBI, Inc. **Attachment A**
 123 Sweeten Creek Rd, Suite A
 Asheville, NC 28803
 Phone: (828) 277-7001
 Fax: (828) 277-7003
 pbiasheville.com



DEPOSIT INVOICE

1266-25925-0

Due Upon Receipt
 2/26/2026

Bill To

Kerry Putnam
 Transylvania County Schools
 225 Rosenwald Lane
 Brevard, NC 28712

Install To / End User

Transylvania County Schools
 Davidson River School
 970 Ecusta Rd
 Brevard, NC 28712

PROJECT #	SALESPERSON	QUOTE NAME	PROJECT NAME
1266	Michelle Stevenson	Transylvania County Schools Davidson River	Transylvania County Schools Davidson River Classroom Furniture

Deposit Details Summarized by Phase

Option	Phase	Price	Tax	Total	Deposit Amount
Transylvania County Schools Davidson River Classroom Furniture	Teacher	\$3,519.45	\$237.56	\$3,757.01	\$2,817.76
	Classroom	\$6,720.30	\$453.62	\$7,173.92	\$5,380.44
	CHAIRS	\$4,071.90	\$274.85	\$4,346.75	\$3,260.06
Total		\$14,311.65	\$966.04	\$15,277.69	\$11,458.26

Order Total	\$14,311.65
Sales Tax	\$966.04
Total	\$15,277.69
75% Deposit Due	\$11,458.26



Transylvania County Schools

PRICE PROPOSAL

Date: 2/26/2026

Prepared For: Mike Galloway

Quote Number: 1260-25920

Valid For 29 Days

Prepared by: Michelle Stevenson

Confidential

© 2026 PBI, Inc..The information in this transmittal is proprietary to PBI, Inc.. It is provided on the condition that it remains in confidence between PBI, Inc. and the recipient of this quote. Do Not Copy, Distribute nor Share the Contents of this proposal without the written permission of PBI, Inc..



Project Scope

Bill To

Kerry Putnam
 Transylvania County Schools
 225 Rosenwald Lane
 Brevard, NC 28712

Project Investment

Project Total	\$17,109.80
Tax (6.75%)	\$1,154.91
Grand Total	\$18,264.71

Install To

Mike Galloway
 Transylvania County Schools
 Brevard High School
 609 N Country Club Rd
 Brevard, NC 28712

Payment Schedule

75% Deposit / Net 30 Days

75% Deposit / Net 30 Days	\$13,698.54
---------------------------	-------------

Price Summary by Phase

Option	Phase / TAG	Price	Tax	Total
Transylvania County Schools Brevard High School Furniture Full Science Classroom	Science Classroom	\$17,109.80	\$1,154.91	\$18,264.71
		\$17,109.80	\$1,154.91	\$18,264.71
Grand Total		\$17,109.80	\$1,154.91	\$18,264.71

PBI, Inc. **Attachment A**
 123 Sweeten Creek Rd, Suite A
 Asheville, NC 28803
 Phone: (828) 277-7001
 Fax: (828) 277-7003
 pbiasheville.com



QUOTATION

1260-25920

VALID UNTIL 3/27/2026

BILL TO

Kerry Putnam
 Transylvania County Schools
 225 Rosenwald Lane
 Brevard, NC 28712

INSTALL TO

Mike Galloway
 Transylvania County Schools
 Brevard High School
 609 N Country Club Rd
 Brevard, NC 28712

Salesperson
 Michelle Stevenson

Payment Terms
 75% Deposit / Net 30 Days

All KI pricing per NC State Contract. Shipping from factory included.

Transylvania County Schools Brevard High School Furniture Full Science Classroom

Science Classroom

LINE #	QTY	UNIT	PART # / DESCRIPTION	PRICE EA	EXT PRICE
1	1.00	EA	Furniture Labor / Installation / Labor to receive, deliver and install during normal business hours.	\$1,001.00	\$1,001.00
2	16.00	EA	P7144K30N / TABLE, FIXED HEIGHT, 30H x 60in Wide x 30in Deep 0.75 INCH PHENOLIC TOP, PLAIN 2-1/4" solid square legs, with 5/16" hanger bolts installed, supplied nuts and washers 3/4" Phenolic Worksurface Aprons are 13/16"D x 4-1/2"H with heavy-duty 13 gauge steel corner braces Finished natural with a chemical resistant UV finish Minimal assembly required; legs need to be attached Solid Wood Construction Tables are equipped with non-skid adjustable glides for precise leveling and rubber leg boots Top Size 60"W x 30"D Weight capacity is 500lbs evenly distributed Wood: Red Oak Stain:Northwoods	\$721.15	\$11,538.40
3	1.00	EA	Furniture Freight / Freight quoted for 16 tables. Quote expires 3/31/26. Will need to requote for order.	\$1,196.00	\$1,196.00
4	32.00	EA	IW418 / Intellect Wave 4-Leg Chair, Large, 18"H OPTIONS /NG Nylon Glides (Glide Option) /RCK Racked (Carton Code Option) /CH Chrome (Intellect Wave Frame Color) /NFR No Fire Retardant (Shell Color) /PND Nordic (Shell NFR)	\$105.45	\$3,374.40



CUSTOMER SIGN OFF

subtotal	\$17,109.80
sales tax	\$1,154.91
total	\$18,264.71

 Authorized Signature

 Accepted Date

 Print Name



PBI Terms and Conditions

Disclaimer:

-PO and/or Signature along with materials deposit required to process order. We appreciate this opportunity and look forward to a successful project!

-All prices are based on information discussed. Budgets can vary based on the final selections of materials and accessories. PBI's services are figured for normal business hours unless discussed otherwise. PBI has included all known elements within this good faith estimate. If unknown issues arise, they will be discussed with the team to determine best plan of action to proceed.

-PBI orders are specific to each client/project. Any orders changed or cancelled after order processing will result in change fees, full materials charge, or applicable restocking fees.

-75% deposit required unless client has been approved for credit terms

-PBI to invoice based on progress of job which will include materials delivered to site and/or stored materials in PBI warehouse.

-Storage Fee of \$350 per week will be charged on goods held over 30 days unless arrangements have been made.

-PBI accepts credit card transactions with a 4% transaction fee.

-PBI, Inc reserves the right to raise the material price on this proposal by the percentage increase of any publicly announced tariff that may take place before this proposal is accepted by the (customer/client). If PBI, Inc is awarded the contract, any price increase of material due to tariffs during the performance of the contract through no fault of the Contractor, the contract sum shall be equitably adjusted by change order in accordance with the procedures of the contract documents. A change in price of an item of material shall be considered significant when the price of an item increases 10% or more between the date of the contract and the date of installation.

-Phased installations, trips, and material deliveries to be determined prior to signed proposal. Any additions or changes will result in additional charges. Job sites must have clear and safe access for delivery.

Additional Terms for Flooring-Construction- Windows and Doors

-Any unforeseen circumstances will be discussed with the owner/project manager and additional charges may apply.

- Flooring installation requires-All HVAC and Lighting to be in operation prior to installation. PBI excludes the following unless otherwise noted in proposal: Floor Leveling; Moisture Mitigation; Nights/Weekends; Floor Protection; Expansion Joints; Dumpsters.

-PBI cannot accept responsibility for costs that may be associated with delays and product production and delivery to job site.

-All products delivered to jobsite must be inspected at time of delivery and will require signature. PBI will only accept responsibility for noted missing or damaged items.

PBI, Inc. **Attachment A**
 123 Sweeten Creek Rd, Suite A
 Asheville, NC 28803
 Phone: (828) 277-7001
 Fax: (828) 277-7003
 pbiasheville.com



DEPOSIT INVOICE

1260-25920-0

Due Upon Receipt
 2/26/2026

Bill To

Kerry Putnam
 Transylvania County Schools
 225 Rosenwald Lane
 Brevard, NC 28712

Install To / End User

Mike Galloway
 Transylvania County Schools
 Brevard High School
 609 N Country Club Rd
 Brevard, NC 28712

PROJECT #	SALESPERSON	QUOTE NAME	PROJECT NAME
1260	Michelle Stevenson	Transylvania County Schools Brevard High School	Transylvania County Schools Brevard High School Furniture Full Classroom

Deposit Details Summarized by Phase

Option	Phase	Price	Tax	Total	Deposit Amount
Transylvania County Schools Brevard High School Furniture Full Science Classroom	Science Classroom	\$17,109.80	\$1,154.91	\$18,264.71	\$13,698.54
Total		\$17,109.80	\$1,154.91	\$18,264.71	\$13,698.54

Order Total	\$17,109.80
Sales Tax	\$1,154.91
Total	\$18,264.71
75% Deposit Due	\$13,698.54



Transylvania County Schools

PRICE PROPOSAL

Date: 2/26/2026

Prepared For: Mike Galloway

Quote Number: 1263-25923

Valid For 30 Days

Prepared by: Michelle Stevenson

Confidential

© 2026 PBI, Inc..The information in this transmittal is proprietary to PBI, Inc.. It is provided on the condition that it remains in confidence between PBI, Inc. and the recipient of this quote. Do Not Copy, Distribute nor Share the Contents of this proposal without the written permission of PBI, Inc..



Project Scope

Bill To

Kerry Putnam
 Transylvania County Schools
 225 Rosenwald Lane
 Brevard, NC 28712

Project Investment

Project Total	\$12,763.02
Tax (6.75%)	\$861.50
Grand Total	\$13,624.52

Install To

Mike Galloway
 Transylvania County Schools
 Brevard High School
 609 N Country Club Rd
 Brevard, NC 28712

Payment Schedule

75% Deposit / Net 30 Days

75% Deposit / Net 30 Days	\$10,218.39
---------------------------	-------------

Price Summary by Phase

Option	Phase / TAG	Price	Tax	Total
Transylvania County Schools Brevard High School Full Classroom Furniture	Classroom Furniture	\$12,763.02	\$861.50	\$13,624.52
		\$12,763.02	\$861.50	\$13,624.52
Grand Total		\$12,763.02	\$861.50	\$13,624.52

BILL TO
 Kerry Putnam
 Transylvania County Schools
 225 Rosenwald Lane
 Brevard, NC 28712

INSTALL TO
 Mike Galloway
 Transylvania County Schools
 Brevard High School
 609 N Country Club Rd
 Brevard, NC 28712



Salesperson
 Michelle Stevenson

Payment Terms
 75% Deposit / Net 30 Days

All KI and SOI pricing per NC State contract.

Transylvania County Schools Brevard High School Full Classroom Furniture

Classroom Furniture

LINE #	QTY	UNIT	PART # / DESCRIPTION	PRICE EA	EXT PRICE
1	29.00	EA	RDEEA2030-73P / Ruckus,Fixed Height Post-Leg Desk 28-1/2",Rectangle,3/4"Top,73P Edge,20x30"	\$267.90	\$7,769.10
 <p>OPTIONS</p> <ul style="list-style-type: none"> /EKM Kensington Maple Edge (Edge Color) LAMG1 Laminate Grade 1 (Laminate) LAMGRD1STD Grade 1 Ki Standard Laminates (Laminate Finish) /LKM Kensington Maple 10776-60 (Grade 1 KI standard laminates) /CH Chrome (Base Finish) /GNY Nylon Glides (Caster/Glides) /NB No Book Storage (Under Table Storage) 					
2	1.00	EA	RDEEA2030-73P / Ruckus,Sit Height Adjustable Post-Leg Desk 19-1/2 to 32-1/2",Rectangle,3/4"Top,73P Edge,20x30"	\$299.82	\$299.82
 <p>OPTIONS</p> <ul style="list-style-type: none"> /EKM Kensington Maple Edge (Edge Color) LAMG1 Laminate Grade 1 (Laminate) LAMGRD1STD Grade 1 Ki Standard Laminates (Laminate Finish) /LKM Kensington Maple 10776-60 (Grade 1 KI standard laminates) /CH Chrome (Base Finish) /GNY Nylon Glides (Caster/Glides) /NB No Book Storage (Under Table Storage) 					
3	30.00	EA	RKUSBBH1 / Ruckus,Book Bag Hook Kit,Chrome	\$5.70	\$171.00
4	30.00	EA	CGG100H18 / Cogni Cantilever Chair, Glide Base, Poly, Large 18"H	\$125.97	\$3,779.10
 <p>OPTIONS</p> <ul style="list-style-type: none"> /CH Chrome (Frame Color) /PND Nordic (Shell Color) /GPL Nylon Plastic Glides (Glide Option) /BBL Black (Glide/Wheel Color) /RCK Racked (Minimum Quantity To Rack Is 15) (Packaging Option) 					
5	1.00	EA	Furniture Labor / Installation / Labor to receive, deliver and install during normal business hours.	\$744.00	\$744.00

PBI, Inc. **Attachment A**
123 Sweeten Creek Rd, Suite A
Asheville, NC 28803
Phone: (828) 277-7001
Fax: (828) 277-7003
pbiasheville.com



QUOTATION

1263-25923

VALID UNTIL 3/28/2026

Transylvania County Schools Brevard High School Full Classroom Furniture

CUSTOMER SIGN OFF

subtotal	\$12,763.02
sales tax	\$861.50
total	\$13,624.52

Authorized Signature

Accepted Date

Print Name



PBI Terms and Conditions

Disclaimer:

-PO and/or Signature along with materials deposit required to process order. We appreciate this opportunity and look forward to a successful project!

-All prices are based on information discussed. Budgets can vary based on the final selections of materials and accessories. PBI's services are figured for normal business hours unless discussed otherwise. PBI has included all known elements within this good faith estimate. If unknown issues arise, they will be discussed with the team to determine best plan of action to proceed.

-PBI orders are specific to each client/project. Any orders changed or cancelled after order processing will result in change fees, full materials charge, or applicable restocking fees.

-75% deposit required unless client has been approved for credit terms

-PBI to invoice based on progress of job which will include materials delivered to site and/or stored materials in PBI warehouse.

-Storage Fee of \$350 per week will be charged on goods held over 30 days unless arrangements have been made.

-PBI accepts credit card transactions with a 4% transaction fee.

-PBI, Inc reserves the right to raise the material price on this proposal by the percentage increase of any publicly announced tariff that may take place before this proposal is accepted by the (customer/client). If PBI, Inc is awarded the contract, any price increase of material due to tariffs during the performance of the contract through no fault of the Contractor, the contract sum shall be equitably adjusted by change order in accordance with the procedures of the contract documents. A change in price of an item of material shall be considered significant when the price of an item increases 10% or more between the date of the contract and the date of installation.

-Phased installations, trips, and material deliveries to be determined prior to signed proposal. Any additions or changes will result in additional charges. Job sites must have clear and safe access for delivery.

Additional Terms for Flooring-Construction- Windows and Doors

-Any unforeseen circumstances will be discussed with the owner/project manager and additional charges may apply.

- Flooring installation requires-All HVAC and Lighting to be in operation prior to installation. PBI excludes the following unless otherwise noted in proposal: Floor Leveling; Moisture Mitigation; Nights/Weekends; Floor Protection; Expansion Joints; Dumpsters.

-PBI cannot accept responsibility for costs that may be associated with delays and product production and delivery to job site.

-All products delivered to jobsite must be inspected at time of delivery and will require signature. PBI will only accept responsibility for noted missing or damaged items.

PBI, Inc. **Attachment A**
 123 Sweeten Creek Rd, Suite A
 Asheville, NC 28803
 Phone: (828) 277-7001
 Fax: (828) 277-7003
 pbiasheville.com



DEPOSIT INVOICE

1263-25923-0

Due Upon Receipt
 2/26/2026

Bill To

Kerry Putnam
 Transylvania County Schools
 225 Rosenwald Lane
 Brevard, NC 28712

Install To / End User

Mike Galloway
 Transylvania County Schools
 Brevard High School
 609 N Country Club Rd
 Brevard, NC 28712

PROJECT #	SALESPERSON	QUOTE NAME	PROJECT NAME
1263	Michelle Stevenson	Transylvania County Schools Brevard High School Full	Transylvania County Schools Brevard High School Full Classroom Furniture

Deposit Details Summarized by Phase

Option	Phase	Price	Tax	Total	Deposit Amount
Transylvania County Schools Brevard High School Full Classroom Furniture	Classroom Furniture	\$12,763.02	\$861.50	\$13,624.52	\$10,218.39
Total		\$12,763.02	\$861.50	\$13,624.52	\$10,218.39

Order Total	\$12,763.02
Sales Tax	\$861.50
Total	\$13,624.52
75% Deposit Due	\$10,218.39



Transylvania County Schools

PRICE PROPOSAL

Date: 2/26/2026

Prepared For: Mike Galloway

Quote Number: 1265-25924

Valid For 30 Days

Prepared by: Michelle Stevenson

Confidential

© 2026 PBI, Inc..The information in this transmittal is proprietary to PBI, Inc.. It is provided on the condition that it remains in confidence between PBI, Inc. and the recipient of this quote. Do Not Copy, Distribute nor Share the Contents of this proposal without the written permission of PBI, Inc..



Project Scope

Bill To

Kerry Putnam
 Transylvania County Schools
 225 Rosenwald Lane
 Brevard, NC 28712

Install To

Mike Galloway
 Transylvania County Schools
 Brevard High School
 609 N Country Club Rd
 Brevard, NC 28712

Project Investment

Project Total	\$3,744.45
Tax (6.75%)	\$252.75
Grand Total	\$3,997.20

Payment Schedule

75% Deposit / Net 30 Days

75% Deposit / Net 30 Days	\$2,997.90
---------------------------	------------

Price Summary by Phase

Option	Phase / TAG	Price	Tax	Total
Transylvania County Schools Brevard High Teacher Furniture	Teacher labor	\$225.00	\$15.19	\$240.19
	Teacher	\$3,519.45	\$237.56	\$3,757.01
		\$3,744.45	\$252.75	\$3,997.20
Grand Total		\$3,744.45	\$252.75	\$3,997.20

BILL TO
 Kerry Putnam
 Transylvania County Schools
 225 Rosenwald Lane
 Brevard, NC 28712

INSTALL TO
 Mike Galloway
 Transylvania County Schools
 Brevard High School
 609 N Country Club Rd
 Brevard, NC 28712

Salesperson
 Michelle Stevenson

Payment Terms
 75% Deposit / Net 30 Days

All Ki and SOI Pricing per NC State Contract. Shipping from factory included.

Transylvania County Schools Brevard High Teacher Furniture

Teacher labor

LINE #	QTY	UNIT	PART # / DESCRIPTION	PRICE EA	EXT PRICE
1	1.00	EA	Furniture Labor / Installation / Labor to receive, deliver and install during normal business hours.	\$225.00	\$225.00

Teacher

LINE #	QTY	UNIT	PART # / DESCRIPTION	PRICE EA	EXT PRICE
2	1.00	EA	1203.BK2.MB.FE3.AR4 / Hexy, Highback, Mesh Back, Standard Synchro w/Seat Depth Adj, Height/Adjustable Arms	\$466.65	\$466.65
			 OPTIONS CH1 Standard Cylinder (Cylinder Height Option) FC1 Black Frame (Frame Color Selection) BT2 5 Star Polished Aluminum Base(For Any Frame Color) (Base Selection) CS6 Hard Floor And Carpet Casters (Caster Selection) MC21 Nickel Mesh (Hexy Mesh Back Colors) US Upholstered Seat (Hexy Upholstered Seat Material Selection) FG2 Fabric/Vinyl Grade 2 (Fabric Grade Selections) ELEMENT Element Color Selection (Fabric Grade 2 Selection) CHARCOAL Element Charcoal (Element Color Selection) UC Back Attached To Seat, Base Separate (Packaging Options)		
3	1.00	EA	1191SW19S2.US.UB.AR0 / Cora 30" Bar Stool, Armless	\$299.70	\$299.70
			 OPTIONS FC2 Silver Frame (Frame Information) GL2 Performance Multi-Surface Glides (Caster/Glide Option Selection) ~ No Moisture Barrier (Moisture Barrier) USU Single Upholstered (Fabric Option) ~ No Ballistic Nylon Option (Ballistic Nylon Option Selection) FG2 Fabric/Vinyl Grade 2 (CORA Single Upholstered) ELEMENT Element Color Selection (Fabric Grade 2 Selection) CHARCOAL Element Charcoal (Element Color Selection) AC Fully Assembled In Carton (Packaging Options)		
4	1.00	EA	INTDLR2460 / Instruct Teacher Pedestal Desk,D-Shape Top,T-Leg,Laminate Mod. Panel,BBF Ped Right,24Dx60Wx29H,74P edge	\$913.14	\$913.14
			OPTIONS /USP Nickel Arc (Pull Option) LAMG1 Laminate Grade 1 (Laminate) LAMGRD1STD Grade 1 Ki Standard Laminates (Laminate Finish) /LDR Designer White D354-60 (Grade 1 Ki standard laminates) /EDR Designer White Edge (Edge Color) /SX Starlight Silver Metallic (Paint Color) /KA Key Alike (Lock Option) /SCL Satin Chrome (Lock Color)		

PBI, Inc. **Attachment A**
 123 Sweeten Creek Rd, Suite A
 Asheville, NC 28803
 Phone: (828) 277-7001
 Fax: (828) 277-7003
 pbiasheville.com



QUOTATION

1265-25924

VALID UNTIL 3/28/2026

Transylvania County Schools Brevard High Teacher Furniture

Teacher

LINE #	QTY	UNIT	PART # / DESCRIPTION	PRICE EA	EXT PRICE
5	1.00	EA	ATMTDP2466-74P-WSL-S3 / All Terrain Mobile Instructors Desk,Steel Door,Aluminum Bow Tie Pull,Left Worksurface,66"	\$1,839.96	\$1,839.96
					
OPTIONS					
LAMG1 Laminate Grade 1 (Laminate) LAMGRD1STD Grade 1 Ki Standard Laminates (Laminate Finish) /LDR Designer White D354-60 (Grade 1 Ki standard laminates) /SX Starlight Silver Metallic (Unit Color) /KA Key Alike (Lock Option) /SCL Satin Chrome (Lock Color) /L107 Key Alike Lock #107 (National Key Alike) /EDR Designer White Edge (Edge Color)					

CUSTOMER SIGN OFF

subtotal	\$3,744.45
sales tax	\$252.75
total	\$3,997.20

 Authorized Signature

 Accepted Date

 Print Name



PBI Terms and Conditions

Disclaimer:

-PO and/or Signature along with materials deposit required to process order. We appreciate this opportunity and look forward to a successful project!

-All prices are based on information discussed. Budgets can vary based on the final selections of materials and accessories. PBI's services are figured for normal business hours unless discussed otherwise. PBI has included all known elements within this good faith estimate. If unknown issues arise, they will be discussed with the team to determine best plan of action to proceed.

-PBI orders are specific to each client/project. Any orders changed or cancelled after order processing will result in change fees, full materials charge, or applicable restocking fees.

-75% deposit required unless client has been approved for credit terms

-PBI to invoice based on progress of job which will include materials delivered to site and/or stored materials in PBI warehouse.

-Storage Fee of \$350 per week will be charged on goods held over 30 days unless arrangements have been made.

-PBI accepts credit card transactions with a 4% transaction fee.

-PBI, Inc reserves the right to raise the material price on this proposal by the percentage increase of any publicly announced tariff that may take place before this proposal is accepted by the (customer/client). If PBI, Inc is awarded the contract, any price increase of material due to tariffs during the performance of the contract through no fault of the Contractor, the contract sum shall be equitably adjusted by change order in accordance with the procedures of the contract documents. A change in price of an item of material shall be considered significant when the price of an item increases 10% or more between the date of the contract and the date of installation.

-Phased installations, trips, and material deliveries to be determined prior to signed proposal. Any additions or changes will result in additional charges. Job sites must have clear and safe access for delivery.

Additional Terms for Flooring-Construction- Windows and Doors

-Any unforeseen circumstances will be discussed with the owner/project manager and additional charges may apply.

- Flooring installation requires-All HVAC and Lighting to be in operation prior to installation. PBI excludes the following unless otherwise noted in proposal: Floor Leveling; Moisture Mitigation; Nights/Weekends; Floor Protection; Expansion Joints; Dumpsters.

-PBI cannot accept responsibility for costs that may be associated with delays and product production and delivery to job site.

-All products delivered to jobsite must be inspected at time of delivery and will require signature. PBI will only accept responsibility for noted missing or damaged items.

PBI, Inc. **Attachment A**
 123 Sweeten Creek Rd, Suite A
 Asheville, NC 28803
 Phone: (828) 277-7001
 Fax: (828) 277-7003
 pbiasheville.com



DEPOSIT INVOICE

1265-25924-0

Due Upon Receipt
 2/26/2026

Bill To

Kerry Putnam
 Transylvania County Schools
 225 Rosenwald Lane
 Brevard, NC 28712

Install To / End User

Mike Galloway
 Transylvania County Schools
 Brevard High School
 609 N Country Club Rd
 Brevard, NC 28712

PROJECT #	SALESPERSON	QUOTE NAME	PROJECT NAME
1265	Michelle Stevenson	Transylvania County Schools Brevard High Teacher	Transylvania County Schools Brevard High Teacher Furniture

Deposit Details Summarized by Phase

Option	Phase	Price	Tax	Total	Deposit Amount
Transylvania County Schools Brevard High Teacher Furniture	Teacher labor	\$225.00	\$15.19	\$240.19	\$180.14
	Teacher	\$3,519.45	\$237.56	\$3,757.01	\$2,817.76
Total		\$3,744.45	\$252.75	\$3,997.20	\$2,997.90

Order Total	\$3,744.45
Sales Tax	\$252.75
Total	\$3,997.20
75% Deposit Due	\$2,997.90



Transylvania County Schools

PRICE PROPOSAL

Date: 2/26/2026

Prepared For: Jason Ormsby

Quote Number: 1246-25910

Valid For 29 Days

Prepared by: Michelle Stevenson

Confidential

© 2026 PBI, Inc..The information in this transmittal is proprietary to PBI, Inc.. It is provided on the condition that it remains in confidence between PBI, Inc. and the recipient of this quote. Do Not Copy, Distribute nor Share the Contents of this proposal without the written permission of PBI, Inc..



Project Scope

Bill To

Kerry Putnam
 Transylvania County Schools
 225 Rosenwald Lane
 Brevard, NC 28712

Project Investment

Project Total	\$11,329.70
Tax (6.75%)	\$764.75
Grand Total	\$12,094.45

Install To

Jason Ormsby
 Transylvania County Schools
 Rosman High School
 749 Pickens Hwy
 Rosman, NC 28772

Payment Schedule

75% Deposit / Net 30 Days

75% Deposit / Net 30 Days	\$9,070.84
---------------------------	------------

Price Summary by Phase

Option	Phase / TAG	Price	Tax	Total
Rosman High School Classroom	Classroom Furniture	\$11,329.70	\$764.75	\$12,094.45
		\$11,329.70	\$764.75	\$12,094.45
Grand Total		\$11,329.70	\$764.75	\$12,094.45

PBI, Inc. **Attachment A**
 123 Sweeten Creek Rd, Suite A
 Asheville, NC 28803
 Phone: (828) 277-7001
 Fax: (828) 277-7003
 pbiasheville.com



QUOTATION

1246-25910

VALID UNTIL 3/27/2026

BILL TO
 Kerry Putnam
 Transylvania County Schools
 225 Rosenwald Lane
 Brevard, NC 28712

INSTALL TO
 Jason Ormsby
 Transylvania County Schools
 Rosman High School
 749 Pickens Hwy
 Rosman, NC 28772



Salesperson
 Michelle Stevenson

Payment Terms
 75% Deposit / Net 30 Days

All KI pricing per NC State Contract. Shipping from factory included.

Rosman High School Classroom

Classroom Furniture

LINE #	QTY	UNIT	PART # / DESCRIPTION	PRICE EA	EXT PRICE
1	29.00	EA	RDEEA2030-73P / Ruckus,Fixed Height Post-Leg Desk 28-1/2",Rectangle,3/4"Top,73P Edge,20x30"	\$229.14	\$6,645.06
 <p>OPTIONS</p> <ul style="list-style-type: none"> /EKM Kensington Maple Edge (Edge Color) LAMG1 Laminate Grade 1 (Laminate) LAMGRD1STD Grade 1 Ki Standard Laminates (Laminate Finish) /LKM Kensington Maple 10776-60 (Grade 1 KI standard laminates) /FN Flannel (Base Finish) /GFT Felt Glides (Caster/Glides) /NB No Book Storage (Under Table Storage) 					
2	1.00	EA	RDEEA2030-73P / Ruckus,Sit Height Adjustable Post-Leg Desk 19-1/2 to 32-1/2",Rectangle,3/4"Top,73P Edge,20x30"	\$257.64	\$257.64
 <p>OPTIONS</p> <ul style="list-style-type: none"> /EKM Kensington Maple Edge (Edge Color) LAMG1 Laminate Grade 1 (Laminate) LAMGRD1STD Grade 1 Ki Standard Laminates (Laminate Finish) /LKM Kensington Maple 10776-60 (Grade 1 KI standard laminates) /FN Flannel (Base Finish) /GNY Nylon Glides (Caster/Glides) /NB No Book Storage (Under Table Storage) 					
3	30.00	EA	RKUSBBH1 / Ruckus,Book Bag Hook Kit,Chrome	\$5.70	\$171.00
4	30.00	EA	CGG100H18 / Cogni Cantilever Chair, Glide Base, Poly, Large 18"H	\$119.70	\$3,591.00
 <p>OPTIONS</p> <ul style="list-style-type: none"> /FN Flannel (Frame Color) /PFN Flannel (Shell Color) /GHY Hybrid Glide (Glide Option) /BBL Black (Glide/Wheel Color) /CTN Cartoned (Packaging Option) 					
5	1.00	EA	Furniture Labor / Installation / Labor to receive, deliver and install during normal business hours.	\$665.00	\$665.00

PBI, Inc. **Attachment A**
123 Sweeten Creek Rd, Suite A
Asheville, NC 28803
Phone: (828) 277-7001
Fax: (828) 277-7003
pbiasheville.com



QUOTATION

1246-25910

VALID UNTIL 3/27/2026

Rosman High School Classroom

CUSTOMER SIGN OFF

subtotal	\$11,329.70
sales tax	\$764.75
total	\$12,094.45

Authorized Signature

Accepted Date

Print Name



PBI Terms and Conditions

Disclaimer:

-PO and/or Signature along with materials deposit required to process order. We appreciate this opportunity and look forward to a successful project!

-All prices are based on information discussed. Budgets can vary based on the final selections of materials and accessories. PBI's services are figured for normal business hours unless discussed otherwise. PBI has included all known elements within this good faith estimate. If unknown issues arise, they will be discussed with the team to determine best plan of action to proceed.

-PBI orders are specific to each client/project. Any orders changed or cancelled after order processing will result in change fees, full materials charge, or applicable restocking fees.

-75% deposit required unless client has been approved for credit terms

-PBI to invoice based on progress of job which will include materials delivered to site and/or stored materials in PBI warehouse.

-Storage Fee of \$350 per week will be charged on goods held over 30 days unless arrangements have been made.

-PBI accepts credit card transactions with a 4% transaction fee.

-PBI, Inc reserves the right to raise the material price on this proposal by the percentage increase of any publicly announced tariff that may take place before this proposal is accepted by the (customer/client). If PBI, Inc is awarded the contract, any price increase of material due to tariffs during the performance of the contract through no fault of the Contractor, the contract sum shall be equitably adjusted by change order in accordance with the procedures of the contract documents. A change in price of an item of material shall be considered significant when the price of an item increases 10% or more between the date of the contract and the date of installation.

-Phased installations, trips, and material deliveries to be determined prior to signed proposal. Any additions or changes will result in additional charges. Job sites must have clear and safe access for delivery.

Additional Terms for Flooring-Construction- Windows and Doors

-Any unforeseen circumstances will be discussed with the owner/project manager and additional charges may apply.

- Flooring installation requires-All HVAC and Lighting to be in operation prior to installation. PBI excludes the following unless otherwise noted in proposal: Floor Leveling; Moisture Mitigation; Nights/Weekends; Floor Protection; Expansion Joints; Dumpsters.

-PBI cannot accept responsibility for costs that may be associated with delays and product production and delivery to job site.

-All products delivered to jobsite must be inspected at time of delivery and will require signature. PBI will only accept responsibility for noted missing or damaged items.



Transylvania County Schools

PRICE PROPOSAL

Date: 2/26/2026

Prepared For: Jason Ormsby

Quote Number: 1261-25921

Valid For 30 Days

Prepared by: Michelle Stevenson

Confidential

© 2026 PBI, Inc..The information in this transmittal is proprietary to PBI, Inc.. It is provided on the condition that it remains in confidence between PBI, Inc. and the recipient of this quote. Do Not Copy, Distribute nor Share the Contents of this proposal without the written permission of PBI, Inc..



Project Scope

Bill To

Kerry Putnam
 Transylvania County Schools
 225 Rosenwald Lane
 Brevard, NC 28712

Project Investment

Project Total	\$3,744.45
Tax (6.75%)	\$252.75
Grand Total	\$3,997.20

Install To

Jason Ormsby
 Transylvania County Schools
 Rosman High School
 749 Pickens Hwy
 Rosman, NC 28772

Payment Schedule

75% Deposit / Net 30 Days

75% Deposit / Net 30 Days	\$2,997.90
---------------------------	------------

Price Summary by Phase

Option	Phase / TAG	Price	Tax	Total
Transylvania County Schools Rosman High School Teacher Furniture	Teacher	\$3,519.45	\$237.56	\$3,757.01
	Default Phase	\$225.00	\$15.19	\$240.19
		\$3,744.45	\$252.75	\$3,997.20
Grand Total		\$3,744.45	\$252.75	\$3,997.20



BILL TO
 Kerry Putnam
 Transylvania County Schools
 225 Rosenwald Lane
 Brevard, NC 28712

INSTALL TO
 Jason Ormsby
 Transylvania County Schools
 Rosman High School
 749 Pickens Hwy
 Rosman, NC 28772



Salesperson
 Michelle Stevenson

Payment Terms
 75% Deposit / Net 30 Days

All KI and SOI priced per NC state contract.

Transylvania County Schools Rosman High School Teacher Furniture

Teacher

LINE #	QTY	UNIT	PART # / DESCRIPTION	PRICE EA	EXT PRICE
1	1.00	EA	1203.BK2.MB.FE3.AR4 / Hexy, Highback, Mesh Back, Standard Synchro w/Seat Depth Adj, Height/Adjustable Arms	\$466.65	\$466.65
			 OPTIONS CH1 Standard Cylinder (Cylinder Height Option) FC1 Black Frame (Frame Color Selection) BT2 5 Star Polished Aluminum Base(For Any Frame Color) (Base Selection) CS6 Hard Floor And Carpet Casters (Caster Selection) MC21 Nickel Mesh (Hexy Mesh Back Colors) US Upholstered Seat (Hexy Upholstered Seat Material Selection) FG2 Fabric/Vinyl Grade 2 (Fabric Grade Selections) ELEMENT Element Color Selection (Fabric Grade 2 Selection) CHARCOAL Element Charcoal (Element Color Selection) UC Back Attached To Seat, Base Separate (Packaging Options)		
2	1.00	EA	1191SW19S2.US.UB.AR0 / Cora 30" Bar Stool, Armless	\$299.70	\$299.70
			 OPTIONS FC2 Silver Frame (Frame Information) GL2 Performance Multi-Surface Glides (Caster/Glide Option Selection) ~ No Moisture Barrier (Moisture Barrier) USU Single Upholstered (Fabric Option) ~ No Ballistic Nylon Option (Ballistic Nylon Option Selection) FG2 Fabric/Vinyl Grade 2 (CORA Single Upholstered) ELEMENT Element Color Selection (Fabric Grade 2 Selection) CHARCOAL Element Charcoal (Element Color Selection) AC Fully Assembled In Carton (Packaging Options)		
3	1.00	EA	INTDLR2460 / Instruct Teacher Pedestal Desk,D-Shape Top,T-Leg,Laminate Mod. Panel,BBF Ped Right,24Dx60Wx29H,74P edge	\$913.14	\$913.14
			OPTIONS /USP Nickel Arc (Pull Option) LAMG1 Laminate Grade 1 (Laminate) LAMGRD1STD Grade 1 Ki Standard Laminates (Laminate Finish) /LDR Designer White D354-60 (Grade 1 Ki standard laminates) /EDR Designer White Edge (Edge Color) /SX Starlight Silver Metallic (Paint Color) /KA Key Alike (Lock Option) /SCL Satin Chrome (Lock Color)		



Transylvania County Schools Rosman High School Teacher Furniture

Teacher

LINE #	QTY	UNIT	PART # / DESCRIPTION	PRICE EA	EXT PRICE
4	1.00	EA	ATMTDP2466-74P-WSL-S3 / All Terrain Mobile Instructors Desk,Steel Door,Aluminum Bow Tie Pull,Left Worksurface,66"	\$1,839.96	\$1,839.96
					
OPTIONS LAMG1 Laminate Grade 1 (Laminate) LAMGRD1STD Grade 1 Ki Standard Laminates (Laminate Finish) /LDR Designer White D354-60 (Grade 1 Ki standard laminates) /SX Starlight Silver Metallic (Unit Color) /KA Key Alike (Lock Option) /SCL Satin Chrome (Lock Color) /L107 Key Alike Lock #107 (National Key Alike) /EDR Designer White Edge (Edge Color)					

Default Phase

LINE #	QTY	UNIT	PART # / DESCRIPTION	PRICE EA	EXT PRICE
5	1.00	EA	Furniture Labor / Installation / Labor to receive, deliver and install during normal business hours.	\$225.00	\$225.00

CUSTOMER SIGN OFF

subtotal	\$3,744.45
sales tax	\$252.75
total	\$3,997.20

 Authorized Signature

 Accepted Date

 Print Name



PBI Terms and Conditions

Disclaimer:

-PO and/or Signature along with materials deposit required to process order. We appreciate this opportunity and look forward to a successful project!

-All prices are based on information discussed. Budgets can vary based on the final selections of materials and accessories. PBI's services are figured for normal business hours unless discussed otherwise. PBI has included all known elements within this good faith estimate. If unknown issues arise, they will be discussed with the team to determine best plan of action to proceed.

-PBI orders are specific to each client/project. Any orders changed or cancelled after order processing will result in change fees, full materials charge, or applicable restocking fees.

-75% deposit required unless client has been approved for credit terms

-PBI to invoice based on progress of job which will include materials delivered to site and/or stored materials in PBI warehouse.

-Storage Fee of \$350 per week will be charged on goods held over 30 days unless arrangements have been made.

-PBI accepts credit card transactions with a 4% transaction fee.

-PBI, Inc reserves the right to raise the material price on this proposal by the percentage increase of any publicly announced tariff that may take place before this proposal is accepted by the (customer/client). If PBI, Inc is awarded the contract, any price increase of material due to tariffs during the performance of the contract through no fault of the Contractor, the contract sum shall be equitably adjusted by change order in accordance with the procedures of the contract documents. A change in price of an item of material shall be considered significant when the price of an item increases 10% or more between the date of the contract and the date of installation.

-Phased installations, trips, and material deliveries to be determined prior to signed proposal. Any additions or changes will result in additional charges. Job sites must have clear and safe access for delivery.

Additional Terms for Flooring-Construction- Windows and Doors

-Any unforeseen circumstances will be discussed with the owner/project manager and additional charges may apply.

- Flooring installation requires-All HVAC and Lighting to be in operation prior to installation. PBI excludes the following unless otherwise noted in proposal: Floor Leveling; Moisture Mitigation; Nights/Weekends; Floor Protection; Expansion Joints; Dumpsters.

-PBI cannot accept responsibility for costs that may be associated with delays and product production and delivery to job site.

-All products delivered to jobsite must be inspected at time of delivery and will require signature. PBI will only accept responsibility for noted missing or damaged items.



Transylvania County Schools

PRICE PROPOSAL

Date: 2/26/2026

Prepared For: Jason Ormsby

Quote Number: 1262-25922

Valid For 30 Days

Prepared by: Michelle Stevenson

Confidential

© 2026 PBI, Inc..The information in this transmittal is proprietary to PBI, Inc.. It is provided on the condition that it remains in confidence between PBI, Inc. and the recipient of this quote. Do Not Copy, Distribute nor Share the Contents of this proposal without the written permission of PBI, Inc..



Project Scope

Bill To

Kerry Putnam
 Transylvania County Schools
 225 Rosenwald Lane
 Brevard, NC 28712

Project Investment

Project Total	\$17,109.80
Tax (6.75%)	\$1,154.91
Grand Total	\$18,264.71

Install To

Jason Ormsby
 Transylvania County Schools
 Rosman High School
 749 Pickens Hwy
 Rosman, NC 28772

Payment Schedule

75% Deposit / Net 30 Days

75% Deposit / Net 30 Days	\$13,698.54
---------------------------	-------------

Price Summary by Phase

Option	Phase / TAG	Price	Tax	Total
Transylvania County Schools Rosman High School Furniture Science Classroom	Science Classrooms	\$17,109.80	\$1,154.91	\$18,264.71
		\$17,109.80	\$1,154.91	\$18,264.71
Grand Total		\$17,109.80	\$1,154.91	\$18,264.71

PBI, Inc. **Attachment A**
 123 Sweeten Creek Rd, Suite A
 Asheville, NC 28803
 Phone: (828) 277-7001
 Fax: (828) 277-7003
 pbiasheville.com



QUOTATION

1262-25922

VALID UNTIL 3/28/2026

BILL TO

Kerry Putnam
 Transylvania County Schools
 225 Rosenwald Lane
 Brevard, NC 28712

INSTALL TO

Jason Ormsby
 Transylvania County Schools
 Rosman High School
 749 Pickens Hwy
 Rosman, NC 28772

Salesperson
 Michelle Stevenson

Payment Terms
 75% Deposit / Net 30 Days

Transylvania County Schools Rosman High School Furniture Science Classroom

Science Classrooms

LINE #	QTY	UNIT	PART # / DESCRIPTION	PRICE EA	EXT PRICE
1	1.00	EA	Furniture Labor / Installation / Labor to receive, deliver and install during normal business hours.	\$1,001.00	\$1,001.00
2	1.00	EA	Furniture Freight / Freight quoted for 16 tables. Quote expires 3/31/26. Will need to requote for order.	\$1,196.00	\$1,196.00
3	16.00	EA	P7144K30N / TABLE, FIXED HEIGHT, 30H x 60in Wide x 30in Deep 0.75 INCH PHENOLIC TOP, PLAIN 2-1/4" solid square legs, with 5/16" hanger bolts installed, supplied nuts and washers 3/4" Phenolic Worksurface Aprons are 13/16"D x 4-1/2"H with heavy-duty 13 gauge steel corner braces Finished natural with a chemical resistant UV finish Minimal assembly required; legs need to be attached Solid Wood Construction Tables are equipped with non-skid adjustable glides for precise leveling and rubber leg boots Top Size 60"W x 30"D Weight capacity is 500lbs evenly distributed Wood: Red Oak Stain:Northwoods	\$721.15	\$11,538.40
4	32.00	EA	IW418 / Intellect Wave 4-Leg Chair, Large, 18"H OPTIONS /NG Nylon Glides (Glide Option) /RCK Racked (Carton Code Option) /CH Chrome (Intellect Wave Frame Color) /NFR No Fire Retardant (Shell Color) /PND Nordic (Shell NFR)	\$105.45	\$3,374.40



CUSTOMER SIGN OFF

subtotal	\$17,109.80
sales tax	\$1,154.91
total	\$18,264.71

 Authorized Signature

 Accepted Date

 Print Name



PBI Terms and Conditions

Disclaimer:

-PO and/or Signature along with materials deposit required to process order. We appreciate this opportunity and look forward to a successful project!

-All prices are based on information discussed. Budgets can vary based on the final selections of materials and accessories. PBI's services are figured for normal business hours unless discussed otherwise. PBI has included all known elements within this good faith estimate. If unknown issues arise, they will be discussed with the team to determine best plan of action to proceed.

-PBI orders are specific to each client/project. Any orders changed or cancelled after order processing will result in change fees, full materials charge, or applicable restocking fees.

-75% deposit required unless client has been approved for credit terms

-PBI to invoice based on progress of job which will include materials delivered to site and/or stored materials in PBI warehouse.

-Storage Fee of \$350 per week will be charged on goods held over 30 days unless arrangements have been made.

-PBI accepts credit card transactions with a 4% transaction fee.

-PBI, Inc reserves the right to raise the material price on this proposal by the percentage increase of any publicly announced tariff that may take place before this proposal is accepted by the (customer/client). If PBI, Inc is awarded the contract, any price increase of material due to tariffs during the performance of the contract through no fault of the Contractor, the contract sum shall be equitably adjusted by change order in accordance with the procedures of the contract documents. A change in price of an item of material shall be considered significant when the price of an item increases 10% or more between the date of the contract and the date of installation.

-Phased installations, trips, and material deliveries to be determined prior to signed proposal. Any additions or changes will result in additional charges. Job sites must have clear and safe access for delivery.

Additional Terms for Flooring-Construction- Windows and Doors

-Any unforeseen circumstances will be discussed with the owner/project manager and additional charges may apply.

- Flooring installation requires-All HVAC and Lighting to be in operation prior to installation. PBI excludes the following unless otherwise noted in proposal: Floor Leveling; Moisture Mitigation; Nights/Weekends; Floor Protection; Expansion Joints; Dumpsters.

-PBI cannot accept responsibility for costs that may be associated with delays and product production and delivery to job site.

-All products delivered to jobsite must be inspected at time of delivery and will require signature. PBI will only accept responsibility for noted missing or damaged items.

Attachment B



PIEDMONT TRUCKS



2024-2029 STATE OF NORTH CAROLINA TERM CONTRACT #2510A-Fleet Vehicles-All Types
 OPTIONS LIST CATEGORY E-MEDIUM SUPER DUTY TRUCKS- F250 Pickup/Chassis
 BID NO. DPC-704600681-BJ

STANDARD ITEMS

10000 GVWR, COLOR: WHITE, 6.8L V-8, GAS ENGINE, TorqShift-G 10-Speed Automatic w/SelectShift®, 3.73 STANDARD REAR AXLE, POWER EQUIPMENT GROUP-POWER WINDOWS/LOCKS, CRUISE CONTROL, TRAILER TOW MIRRORS, SYNC 4 BLUETOOTH, TILT STEERING WHEEL, AIR CONDITIONING, SPARE TIRE-Pickup version only, ALL SEASON TIRES, HEAVY DUTY ALTERNATOR, 40/20/40 VINYL (GRAY) SEATS, TRAILER TOW PACKAGE-2.5" TRAILER HITCH WITH 7&4 WAY TRAILER PLUG, REAR VIEW CAMERA (Pickup version only, deleted with pickup box delete), (2) KEY FOBS

PICKUP / CAB CHASSIS CONFIGURATION	BODY CODE	BASE BID PRICE	
2026 F250 Crew Cab 4x4 pickup-short bed 160wb	W2B-600A		\$46,994.00
		STATE PRICING 6% Discount	
	OPTION	MSRP	
POWERTRAINS			
Electronic-Locking w/3.73 Axle Ratio	X3E	\$430.00	\$404.20
TIRES / WHEELS			
Tires: LT245/75Rx17E BSW A/T	TBM	\$165.00	\$155.10
OTHER OPTIONS			
Trailer Brake Controller (incl. Smart Trailer Tow Connector)	52B	\$300.00	\$282.00
Dual 68 AH/65 AGM Batteries-recommended with Snowplow prep	86M	\$210.00	\$197.40
410 Amp Alternator-required with Dual Batteries	67B	\$215.00	\$202.10
Platform Running Boards-SUPERCAB & CREW CAB ONLY	18B	\$445.00	\$418.30
Upfitter Switches (6) - Located in overhead console	66S	\$250.00	\$235.00
Tough Bed Spray-In Bedliner - Includes tailgate-guard, black box bed tie-down hooks and black bed attachment bolts	85S	\$625.00	\$587.50
110V/400W Outlet - Includes 1 in-dash mounted outlet	43C	\$225.00	\$211.50

Total for pickup & options quote#TCSW2BG160-21026	Date: 2.10.2026	\$49,687.10
--	------------------------	--------------------

Transylvania County Schools
Kerry Putnam
828.885.7376bp kputnam@tcsnc.org

Attachment C



PIEDMONT TRUCKS



2024-2029 STATE OF NORTH CAROLINA TERM CONTRACT #2510A-Fleet Vehicles-All Types
 OPTIONS LIST CATEGORY E-MEDIUM SUPER DUTY TRUCKS- F250 Pickup/Chassis
 BID NO. DPC-704600681-BJ

STANDARD ITEMS

10000 GVWR, COLOR: WHITE, 6.8L V-8, GAS ENGINE, TorqShift-G 10-Speed Automatic w/SelectShift®, 3.73 STANDARD REAR AXLE, POWER EQUIPMENT GROUP-POWER WINDOWS/LOCKS, CRUISE CONTROL, TRAILER TOW MIRRORS, SYNC 4 BLUETOOTH, TILT STEERING WHEEL, AIR CONDITIONING, SPARE TIRE-Pickup version only, ALL SEASON TIRES, HEAVY DUTY ALTERNATOR, 40/20/40 VINYL (GRAY) SEATS, TRAILER TOW PACKAGE-2.5" TRAILER HITCH WITH 7&4 WAY TRAILER PLUG, REAR VIEW CAMERA (Pickup version only, deleted with pickup box delete), (2) KEY FOBS

PICKUP / CAB CHASSIS CONFIGURATION	BODY CODE	BASE BID PRICE	
2026 F250 Crew Cab 4x4 pickup-short bed 160wb	W2B-600A		\$46,994.00
		STATE PRICING 6% Discount	
	OPTION	MSRP	

POWERTRAINS			
Electronic-Locking w/3.73 Axle Ratio	X3E	\$430.00	\$404.20
TIRES / WHEELS			
Tires: LT245/75Rx17E BSW A/T	TBM	\$165.00	\$155.10
OTHER OPTIONS			
Trailer Brake Controller (incl. Smart Trailer Tow Connector)	52B	\$300.00	\$282.00
Dual 68 AH/65 AGM Batteries-recommended with Snowplow prep	86M	\$210.00	\$197.40
410 Amp Alternator-required with Dual Batteries	67B	\$215.00	\$202.10
Platform Running Boards-SUPERCAB & CREW CAB ONLY	18B	\$445.00	\$418.30
Upfitter Switches (6) - Located in overhead console	66S	\$250.00	\$235.00
Tough Bed Spray-In Bedliner - Includes tailgate-guard, black box bed tie-down hooks and black bed attachment bolts	85S	\$625.00	\$587.50
110V/400W Outlet - Includes 1 in-dash mounted outlet	43C	\$225.00	\$211.50

Total for pickup & options quote#TCSW2BG160-21126	Date: 2.11.2026	\$49,687.10
--	------------------------	--------------------

Transylvania County Schools
Keith Wilmot
 828.337.7139cell kwilmot@tcsnc.org

02/25/2026

663770

Quote

Project: NC-Transylvania County-Brevard HS From: Culinary Depot
 Aaron Mensch
 67 Route 59
 Spring Valley, NY 10977
 (888) 845-8200
 845-414-5832 (Contact)

NORTH CAROLINA STATE CONTRACT # STC 5214A

Item	Qty	Description	Sell	Sell Total
1	1 ea	DISHWASHER, CONVEYOR TYPE  Champion 44 PRO Pro Series, 44"W rack conveyor dishwasher, Proportional Rinse, Progressive anti-jam drive system, top mounted control panel with HMI user interface, Proactive maintenance software, 100 gallons per hour with energy sentinel (idle pump shut-off), (209) racks per hour, single-piece hood design, single-piece stainless steel upper & lower wash arms manifolds, single removable scrap screen per tank, 20" standard vertical clearance which accommodate 18" x 26" sheet pans, full 180° opening leak proof insulated hinged access doors, automatic tank fill, door safety switches, leak-proof ball valve drains, lower front & side enclosure panels, stainless steel heavy gauge construction including base & legs, electric tank heat, 2 HP wash pump, single point machine & booster connection, vent fan control, stainless steel rear manifolds, includes: (1) 20" x 20" peg rack & (1) 20" x 20" flat rack, NSF Pot & Pan mode, cULus, ENERGY STAR®, Made in USA	\$22,668.10	\$22,668.10
	1 ea	**NOTE: Please be advised that all quotes provided are valid for a period of 30 days from the date issued. Champion Industries reserves the right to make price adjustments, price increases or add surcharges as appropriate due to tariffs or market fluctuation that are out of our control. Thank you for your understanding.		
	1 ea	1 year parts & labor warranty, standard		
	1 ea	Complimentary factory authorized performance test included, upon equipment start-up. Consult local Champion sales representative for coordination of the start-up. If customer is beyond 60 miles from Champion authorized service agent, consult factory.		

Attachment D

Culinary Depot

02/25/2026

Item	Qty	Description	Sell	Sell Total
	1 ea	Right-to-left operation		
	1 ea	Note: For water of 3-grains of hardness or more, Champion recommends adding a water treatment device.		
	1 ea	901246 Champion ION Scale Prevention System	\$1,541.77	\$1,541.77
	1 ea	480v/60/3-ph		
	1 ea	Electric tank heat, standard		
	1 ea	Electric booster, 70° rise, 21kW, built-in	\$4,006.27	\$4,006.27
	1 ea	20" High hood vertical clearance for sheet pans (standard)		
			Extended Total:	\$28,216.14
			Total	\$28,216.14

Acceptance: _____ Date: _____

Printed Name: _____

Project Grand Total: \$28,216.14

Attachment D

Champion®

The Dishwashing Machine Specialists

PROJECT: _____

ITEM # _____ QTY: _____

MODEL # _____

AIA # _____ SIS # _____

44 PRO-E

HIGH TEMPERATURE ELECTRIC RACK CONVEYOR



Rendered image is for general visual representation only. Please refer to specifications for the latest detailed product information.



STANDARD FEATURES

- **Perpetual Rack Advance System**
with digital jam monitoring, and mechanical drive protection
- **Automated Delime Function**
with user-customizable alert intervals
- **209 Racks Per Hour**
- **0.48 Gallons/Rack With Energy Sentinel** (idle pump shut-off)
- **Advanced Touchscreen Display**
intuitive condition alerts, with user friendly cleaning and operation visual guidance, multi-lingual
- **Enhanced Visual On-board Diagnostics**
quickly identify machine faults for rapid resolution and less downtime
- **Automatic Tank Fill**
- **Programmable Machine Dwell**
pauses rack in wash zone for extended cleaning, NSF Certified Pot & Pan Mode
- **Automatic Drain Valve**
- **Single-Piece Hood Design**
- **Single-Piece Scrap Screen**
more robust and faster cleaning
- **Single-Piece Stainless Steel Upper And Lower Wash Arm Manifolds**
- **Single-Point Electrical Connection**
- **20" Standard Vertical Clearance**
accommodates 18" x 26" sheet pans
- **Fully Insulated Doors**
open a full 180° for unrestricted cleaning access
- **All Stainless Steel Heavy Gauge Construction**
including base, legs and feet
- **Enclosure Panels** (front and sides)
- **2 HP Pump Motor** with stainless steel impeller
- **Factory Authorized Start-Up**
- **Vent Fan Control**
- **ENERGY STAR® Certified**
- **Made in America**

SPECIFIER STATEMENT

Specified unit will be Champion model 44 PRO Series high temperature rack conveyor dishwashing machine. Features top mounted prodigy HMI user interface controls with proactive maintenance software, proportional rinse, using only 100 GPH, optional built-in 21kW booster, progressive anti-jam drive system, energy sentinel (idle pump shut-off), 209 racks per hour, single-piece hood design, single-piece stainless steel upper & lower wash arms manifolds, full 180° opening leak proof insulated hinged access doors.

1 Year parts and labor warranty.

In the USA:

3765 Champion Blvd, Winston-Salem, NC 27105
Tel: (336) 661-1556 Fax: (336) 661-1979
www.championindustries.com

In Canada:

2674 N. Service Rd., Jordan Station, Ontario, Canada LOR1S0
Tel: (905) 562-4195 Fax: (905) 562-4618
www.championindustries.com/icanada

Attachment D**Champion**[®]

The Dishwashing Machine Specialists

44 PRO-E**HIGH TEMPERATURE ELECTRIC RACK CONVEYOR****ACCESSORIES**

- Drain water tempering kit (unmounted)
- Table limit switch, unmounted (recommended on all rack conveyor installations) (unmounted)
 - o WHISKER STYLE
 - o BUTTON STYLE
- Vent cowl, stainless steel with 7" stacks & locking dampers
- Extended vent cowl, with 7" stacks, locking dampers & external curtain
- Flanged feet (unmounted)
- Water hammer kit (unmounted)
- Chemical pump kit (detergent and rinse aid, mounted and interwired)
- Water pressure regulating valve (unmounted; standard with booster)
- ION scale prevention device (unmounted)
- Water softening system (manufactured, warrantied and serviced by Kinetico)
- Dish racks:
 - o PEG RACK
 - o FLAT RACK
 - o SHEET PAN RACK
- Splash shields
- Cantilever sideloader (without hood) for 90° load operation
 - o 24" SIDELOAD
 - o 30" SIDELOAD (ACCEPTS SHEET PANS)
- Model PRO-90B unloader (90° corner conveyor table)
- Model PRO-90B loader (90° corner conveyor table)
- Model RCT 64 or RCT 84 roller conveyor table (see factory for custom length)
- Stainless steel rear enclosure panels
- Correctional package (contact factory)

OPTIONS

- Two-point electrical connection, separate for machine and booster (field convertible)
- 33" Blower dryer – electric
- Booster heaters (completely interplumbed, controls are interwired)
 - o 40°F RISE (BUILT-IN) (FIELD CONVERTED)
 - o 70°F RISE (BUILT-IN)
- Direct link connectivity solution
- Direct link plus+ connectivity solution

**Cantilever
Sideloader**
(no hood)



PRO-90B
90° Corner Conveyor
table loader and
unloader available



Model RCT 64 or RCT 84
Roller conveyor table



In the USA: 3765 Champion Blvd, Winston-Salem, NC 27105 | Tel: (336) 661-1556 Fax: (336) 661-1979 | www.championindustries.com

In Canada: 2674 N. Service Rd., Jordan Station, Ontario, Canada LORISO | Tel: (905) 562-4195 Fax: (905) 562-4618 | www.championindustries.com/icanada

Attachment D



The Dishwashing Machine Specialists

44 PRO-E

HIGH TEMPERATURE ELECTRIC RACK CONVEYOR

UTILITIES

1	Electrical Connections Machine electrical connection and booster electrical connection
2	Hot Water Machine with built-in booster Main connection 1/2" NPT 110° incoming water
4	Hot Water Machine with no booster Main water connection 1/2" NPT 180° incoming water
5A	Drain Connection 1-1/4" NPT Drain Max Flow Rate (g/min) 15
8	Vents A Stack connection – load end 200 CFM @ 1/4" static pressure B Stack connection – unload end 400 CFM @ 1/4" static pressure

Warning: Plumbing and electrical connections should be made by qualified personnel who will observe all the applicable plumbing, sanitary, and safety codes and the National Electrical Code.

Note: Water Hammer Arrestor (meeting ASSE-1010 standard or equivalent) to be supplied (by others) in common water supply line at service connection.

Plumbing Notes: Because of the variation in house-supplied steam and water pressures, steam and water pressure regulating valves (PRVs) may be needed. (Water PRV is standard on machines with booster.) The PRVs can either be purchased from Champion or obtained locally.

Water hardness of 3 grains/US Gal (0.83 Imp Gal) – 5.3 Mg/L or less

Venting Notes: Fabricated duct size: 3-7/8" x 15-7/8" (outside dimensions)

Optional Drain Tempering: 1/2" NPT cold water connection required. 1/2" NPT drain connection from back flow preventer to house drain. (FIELD INSTALLED and PLUMBED).

SPECIFICATIONS

Capacity	
Racks per hr (NSF rated)	209
Wash tank (US gal.)	17
Conveyor speed (ft/min)	5.8
Conveyor speed Pot/Pan Mode (ft/min) (only one rack at a time in pot/pan)	4.5
Motor Horsepower	
Drive	1/6
Wash	2
Water Consumption	
US Gal. per hr (max. use)	100
US Gal. per rack	0.48
Heating	
Tank Heat, electric (kW)	15
Electric booster (built-in) (kW supplied for 40°F rise)	12
Electric booster (built-in) (kW supplied for 70°F rise)	21
Booster heaters completely inter plumbed, controls are interwired.	
Venting	
Load end (minimum CFM)	200
Unload end (minimum CFM)	400
Standard 20" x 20" Rack Complement	
Peg	1
Flat	1

Single Tank PRO Rack Machine and Booster Ratings

The tables below give the ratings for each model. The ratings include the requirements of the 12 and 21 kW booster heaters when they are in use.

Machines with a single point electrical connection:

44 PRO Electric Tank Heat, 21 kW 70° Booster			
Elec. Specs	Rated Amps	Minimum Supply Ckt. Conductor Ampacity	Maximum Overcurrent Protective Device
208/60/3	111	150	150
240/60/3	96	125	125
480/60/3	47	60	60
575/60/3	40	50	50

44 PRO Electric Tank Heat, 12 kW 40° Booster			
Elec. Specs	Rated Amps	Minimum Supply Ckt. Conductor Ampacity	Maximum Overcurrent Protective Device
208/60/3	85	110	110
240/60/3	74	100	100
480/60/3	36	50	50
575/60/3	31	40	40

44 PRO Electric Tank Heat, No Booster			
Elec. Specs	Rated Amps	Minimum Supply Ckt. Conductor Ampacity	Maximum Overcurrent Protective Device
208/60/3	52	70	70
240/60/3	45	60	60
480/60/3	22	30	30
575/60/3	19	25	25

Machines with a dual point electrical connection:

44 PRO Electric, 21 kW Booster Only			
Elec. Specs	Rated Amps	Minimum Supply Ckt. Conductor Ampacity	Maximum Overcurrent Protective Device
208/60/3	59	80	80
240/60/3	51	70	70
480/60/3	26	35	35
575/60/3	22	30	30

44 PRO Electric, 12 kW Booster Only			
Elec. Specs	Rated Amps	Minimum Supply Ckt. Conductor Ampacity	Maximum Overcurrent Protective Device
208/60/3	34	45	45
240/60/3	29	40	40
480/60/3	15	20	20
575/60/3	12	15	15

Note:

Machine ships as a single point electrical connection standard. Easily converted to a dual point connection by a qualified electrician.

In the USA: 3765 Champion Blvd, Winston-Salem, NC 27105 | Tel: (336) 661-1556 Fax: (336) 661-1979 | www.championindustries.com

In Canada: 2674 N. Service Rd., Jordan Station, Ontario, Canada LORISO | Tel: (905) 562-4195 Fax: (905) 562-4618 | www.championindustries.com/icanada

Attachment D

Champion®

The Dishwashing Machine Specialists

44 PRO-E

HIGH TEMPERATURE ELECTRIC RACK CONVEYOR

Shipping weight crated: 600 lbs. Dimensions shown in inches

Front View

Left to Right Model

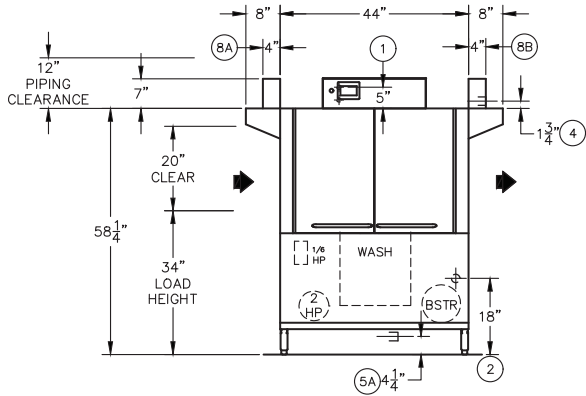

Right to Left Model

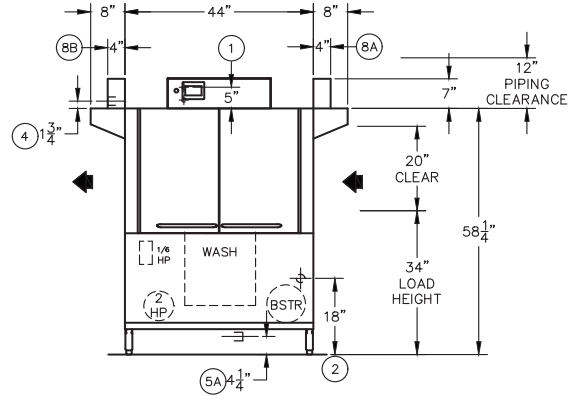

Plan View

Left to Right Model

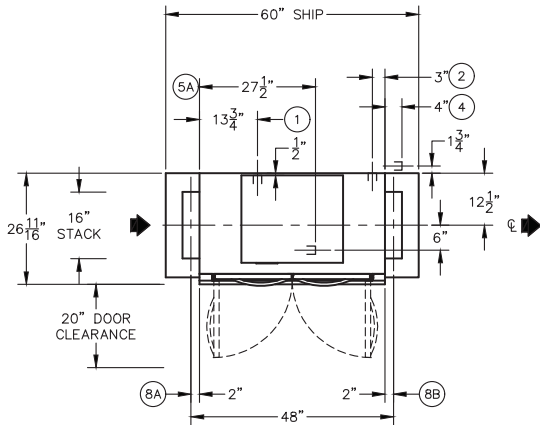

Right to Left Model

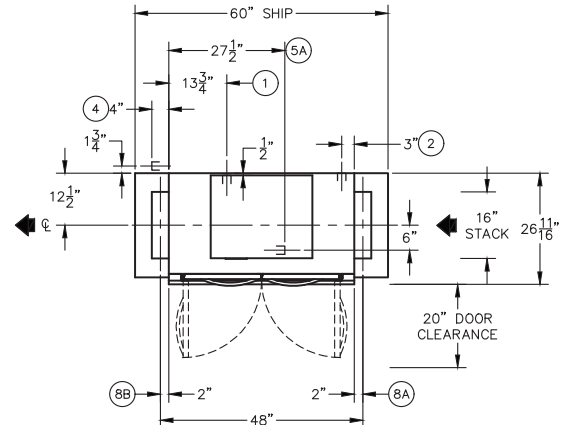

End View

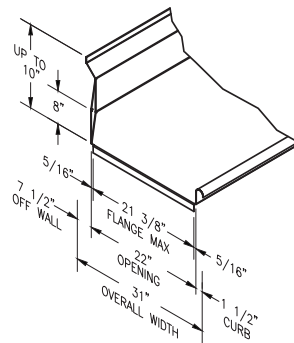
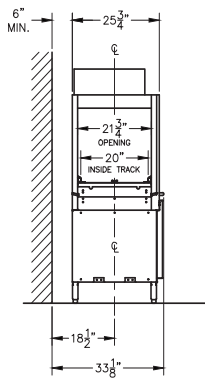

Suggested Table Construction

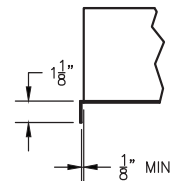

Flange Details

In the USA: 3765 Champion Blvd, Winston-Salem, NC 27105 | Tel: (336) 661-1556 Fax: (336) 661-1979 | www.championindustries.com

In Canada: 2674 N. Service Rd., Jordan Station, Ontario, Canada LORISO | Tel: (905) 562-4195 Fax: (905) 562-4618 | www.championindustries.com/1canada

Rev. 08/2024 Printed in U.S.A.

Due to an ongoing value analysis program at Champion, specifications contained in this catalog are subject to change without notice.



02/25/2026

663774

Quote

Project: NC-Transylvania County-Rosman HS From: Culinary Depot
 Aaron Mensch
 67 Route 59
 Spring Valley, NY 10977
 (888) 845-8200
 845-414-5832 (Contact)

NORTH CAROLINA STATE CONTRACT # STC 5214A

Item	Qty	Description	Sell	Sell Total
1	1 ea	DISHWASHER, CONVEYOR TYPE Champion 66 PRO Pro Series Conveyor Dishwasher, 66"W, (44" single tank + 22" prewash with removable scrap basket), Proportional Rinse, Progressive anti-jam drive system, top mounted control panel with HMI user interface, Proactive maintenance software, 100 gallons per hour with energy sentinel (idle pump shut-off), (209) racks per hour, single-piece hood design, single-piece stainless steel upper & lower wash arms manifolds, internal removable scrap basket, dual-piece scrap screens, 20" standard vertical clearance which accommodate 18" x 26" sheet pans, full 180° opening leak proof insulated hinged access doors, automatic tank fill, door safety switches, leak-proof ball valve drains, lower front & side enclosure panels, stainless steel heavy gauge construction including base & legs, electric tank heat, 2 HP prewash and wash pumps, single point machine & booster connection, vent fan control, stainless steel rear manifolds, NSF Pot & Pan mode, cULus, ENERGY STAR®, Made in USA	\$35,754.86	\$35,754.86
	1 ea	**NOTE: Please be advised that all quotes provided are valid for a period of 30 days from the date issued. Champion Industries reserves the right to make price adjustments, price increases or add surcharges as appropriate due to tariffs or market fluctuation that are out of our control. Thank you for your understanding.		
	1 ea	1 year parts & labor warranty, standard		
	1 ea	Complimentary factory authorized performance test included, upon equipment start-up. Consult local Champion sales representative for		



Item	Qty	Description	Sell	Sell Total
		coordination of the start-up. If customer is beyond 60 miles from Champion authorized service agent, consult factory.		
	1 ea	Left-to-right operation		
	1 ea	Note: For water of 3-grains of hardness or more, Champion recommends adding a water treatment device.		
	1 ea	901246 Champion ION Scale Prevention System	\$1,541.77	\$1,541.77
	1 ea	480v/60/3-ph		
	1 ea	Electric tank heat, standard		
	1 ea	Electric booster, 70° rise, 21kW, built-in	\$4,006.27	\$4,006.27
	1 ea	Custom Extended stainless steel vent cowl with 7" stack to match non-Champion, machine centerline (set)	\$1,777.62	\$1,777.62
	1 ea	20" High hood vertical clearance for sheet pans (standard)		
			Extended Total:	\$43,080.52
			Total	\$43,080.52

Acceptance: _____ Date: _____

Printed Name: _____

Project Grand Total: \$43,080.52

Attachment E**Champion®**

The Dishwashing Machine Specialists

Project _____

Item No. _____

Quantity _____

STANDARD FEATURES

- Perpetual rack advance system, with intuitive jam alert, and drive protection
- Proportional rinse, delivering unmatched total ware coverage, utilizing digital pattern cloning, stainless steel nozzles
- 209 racks per hour
- 100 GPH with energy sentinel (idle pump shut-off)
- Prodigy series HMI display, intuitive condition alerts, with user friendly cleaning and operation visual guidance, multi-lingual, touch control
- Proactive maintenance interface, self-diagnostics, problem recognition, with repair recommendation, from HMI touch screen
- Programmable machine dwell with automatic rack alignment into the optimal wash zone
- **Automatic drain valve *Exclusive!***
- Single-piece hood design
- Single-piece stainless steel upper and lower wash arm manifolds
- Single point electrical connection, machine and built-in booster heater
- 20" standard vertical clearance which accommodates 18" x 26" sheet pans
- Full 180° opening leak proof insulated hinged access doors
- Stainless steel heavy gauge construction including base, legs and feet
- Enclosure panels (front and sides)
- 2 HP pump motor, with stainless steel impeller
- Factory Authorized Start-up
- Vent fan control
- **ENERGY STAR® Qualified**
- **Made in America**

**PRO SERIES****66 PRO Electric**

High Temperature Rack Conveyor Dishwashing Machine



Model 66 PRO shown with vent cowl and damper option



Photo is for general visual representation only. Please refer to specifications for the latest detailed product information.

SPECIFIER STATEMENT

Specified unit will be Champion Model 66 PRO Series high temperature rack conveyor dishwashing machine. Features top mounted Prodigy HMI user interface controls with proactive maintenance software, proportional rinse, using only 100 GPH, built-in 21 kW booster, progressive anti-jam drive system, energy sentinel (idle pump shut-off), 209 racks per hour, single-piece hood design, single-piece stainless steel upper & lower wash arms manifolds, full 180° opening leak proof insulated hinged access doors.

1 year parts and labor warranty.

Champion Industries, Inc.
3765 Champion Blvd., Winston-Salem, NC 27105
Tel: 336/661-1556 Fax: 336/661-1979
www.championindustries.com

Attachment E PRO SERIES

66 PRO Electric
High Temperature Rack Conveyor
Dishwashing Machine

Champion®

The Dishwashing Machine Specialists

MODEL 66 PRO Shipping weight crated: 1,000lbs

Dimensions shown in inches [mm]

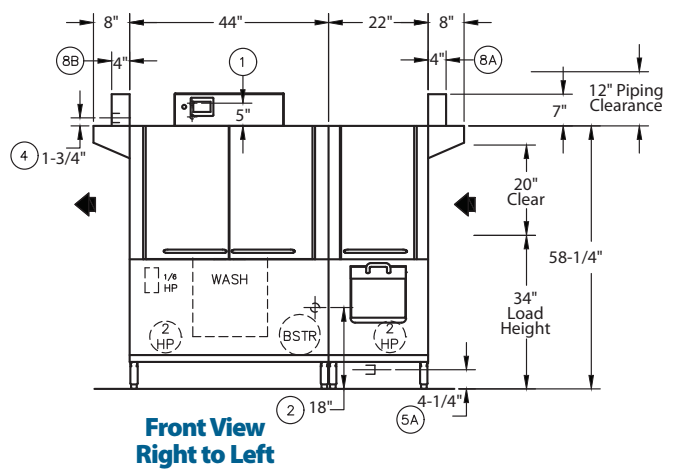
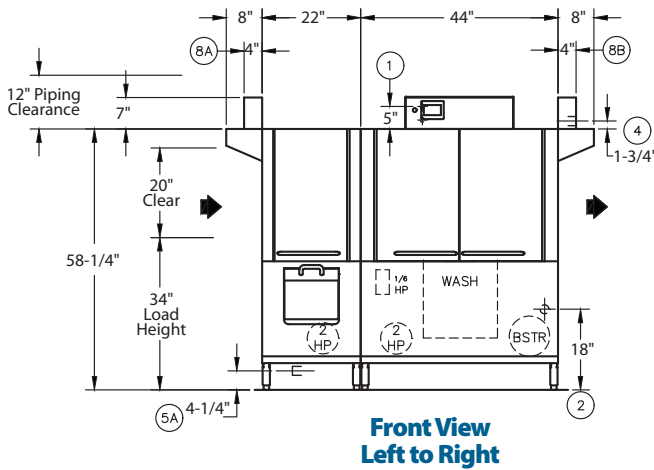

**Plan View
Left to Right**

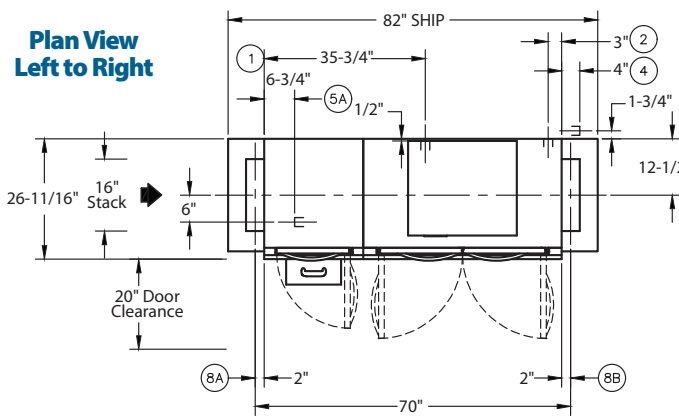

**Plan View
Right to Left**

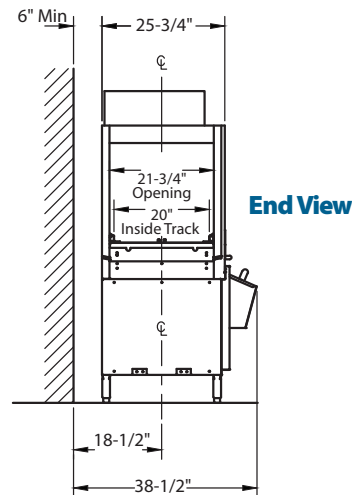
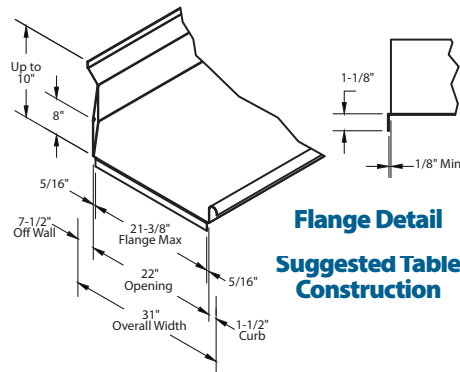
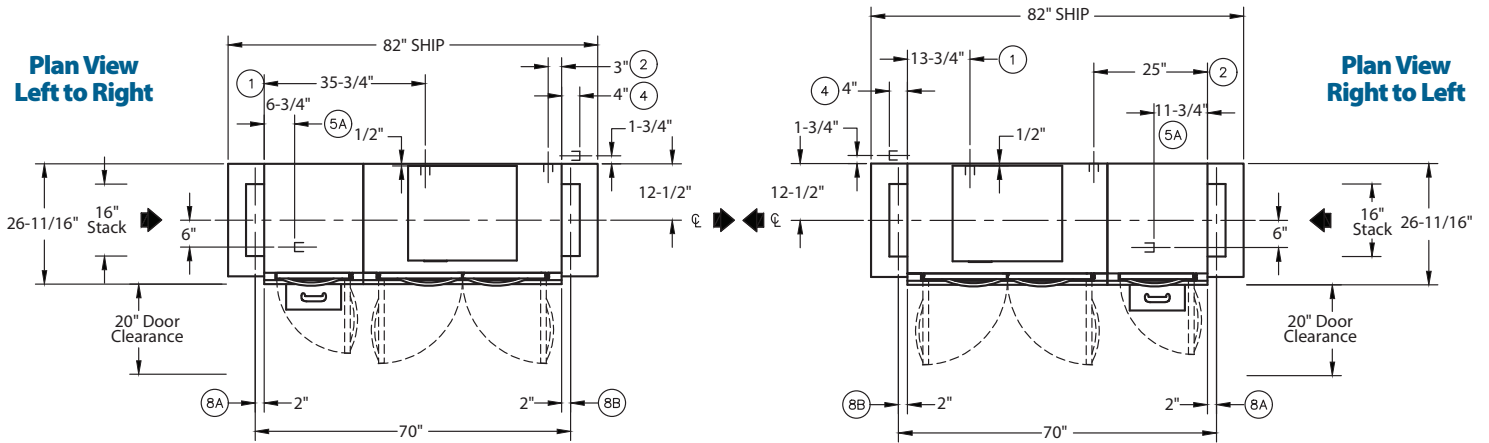

Due to an ongoing value analysis program at Champion, specifications contained in this catalog are subject to change without notice.

Champion Industries, Inc., 3765 Champion Blvd., Winston-Salem, NC 27105 • 336/661-1556 • Fax: 336/661-1979 • www.championindustries.com

Attachment E PRO SERIES

66 PRO Electric

High Temperature Rack Conveyor
Dishwashing Machine



The Dishwashing Machine Specialists

Utilities	
1	Electrical Connection A Machine electrical connection and booster electrical connection
2	Hot Water Machine with built-in booster Main connection 1/2" NPT
4	Hot Water Machine with no booster Main water connection 1/2" NPT
5	Drain Connection 1-1/4" NPT
8	Vents A Stack connection – Load end 200 CFM @ 1/4" static pressure B Stack connection – Unload end 400 CFM @ 1/4" static pressure

Warning: Plumbing and electrical connections should be made by qualified personnel who will observe all the applicable plumbing, sanitary, safety codes and the National Electrical Code.

Note: Water Hammer Arrestor (meeting ASSE-1010 standard or equivalent) to be supplied (by others) in common water supply line at service connection.

Plumbing Notes: Because of the variation in house-supplied steam and water pressures, steam and water pressure regulating valves (PRVs) may be needed. (Water PRV is standard on machines with booster.) The PRVs can either be purchased from Champion or obtained locally.

Venting Notes: Fabricated duct size: 3-7/8" x 15-7/8" (Outside dimensions)

Optional Drain Tempering: 1/2" NPT cold water connection required. 1/2" NPT drain connection from back flow preventer to house drain. (FIELD INSTALLED and PLUMBED).

Single Tank PRO Rack With 22 Prewash Machine and Booster Ratings

The tables below give the ratings for each model. The ratings include the requirements of the 12 and 21 KW booster heaters when they are use.

Machines with a single point electrical connection:

66 PRO Electric Tank Heat, 21 kW 70° Booster			
Electrical Specifications	Rated Amps	Minimum Supply Circuit Ampacity	Maximum Overcurrent Protective Device
208/60/3	116	150	150
240/60/3	101	150	150
480/60/3	50	70	70
575/60/3	42	60	60

66 PRO Electric Tank Heat, 12 kW 40° Booster			
Electrical Specifications	Rated Amps	Minimum Supply Circuit Ampacity	Maximum Overcurrent Protective Device
208/60/3	91	125	125
240/60/3	79	100	100
480/60/3	39	50	50
575/60/3	33	45	45

66 PRO Electric Tank Heat, No Booster			
Electrical Specifications	Rated Amps	Minimum Supply Circuit Ampacity	Maximum Overcurrent Protective Device
208/60/3	58	80	80
240/60/3	50	70	70
480/60/3	25	35	35
575/60/3	21	30	30

SPECIFICATIONS

Capacity

Racks per hr. (NSF rated)	209
Wash/Pre-wash tanks (US gal.)	27
Conveyor speed (ft/min.)	5.8

Motor Horsepower

Drive	1/6
Wash	2
Pre-Wash	2

Water Consumption

US Gal. per hr. (max. use)	100
US Gal. per rack	0.48

Heating

Tank Heat, electric (kW)	15
Electric booster (built-in) (kW supplied for 40°F rise)	12
Electric booster (built-in) (kW supplied for 70°F rise)	21

Booster heaters completely inter plumbed, controls are intertwined

Venting

Load end (minimum CFM)	200
Unload end (minimum CFM)	400

Standard 20" x 20" rack complement

Peg	1
Flat	1

Machines with a dual point electrical connection:

66 PRO Electric 21 kW Booster Only			
Electrical Specifications	Rated Amps	Minimum Supply Circuit Ampacity	Maximum Overcurrent Protective Device
208/60/1	101	125	125
208/60/3	59	80	80
240/60/1	88	110	110
240/60/3	51	70	70
480/60/3	26	35	35
575/60/3	22	30	30

66 PRO Electric 12 kW Booster Only			
Electrical Specifications	Rated Amps	Minimum Supply Circuit Ampacity	Maximum Overcurrent Protective Device
208/60/1	58	80	80
208/60/3	34	45	45
240/60/1	50	70	70
240/60/3	29	40	40
480/60/3	15	20	20
575/60/3	12	15	15

Due to an ongoing value analysis program at Champion, specifications contained in this catalog are subject to change without notice.

Attachment E PRO SERIES

66 PRO Electric

High Temperature Rack Conveyor
Dishwashing Machine

OPTIONS & ACCESSORIES

- Tank heat: choice of steam coil, electric
- Two-Point electrical connection, separate for machine and booster (completed in the field by a licensed electrician)
- 33" Blower-dryer – steam or electric (*see Blower Dryer spec sheet*)
- Booster Heaters (completely interplumbed, controls are interwired)
 - Steam: 40°F or 70°F rise (*see 66 PRO steam spec sheet*)
 - Electric: 40-70°F rise (built-in only)
- 24" Sideload
- 30" Sideload (accepts sheet pans)
- Racks: peg or flat racks (specify type)
- Table limit switch, unmounted (recommended on all rack conveyor installations)
- Vent cowl, stainless steel with 7" stack and locking damper
- Water pressure regulating valve (unmounted) (standard with booster)
- Water hammer kit (unmounted)
- Drain tempering kit (unmounted)
- PRO-90B Unloader (90° Corner Conveyor Table)
- Model RCT 64 or RCT 84 Roller Conveyor Table (See factory for custom length)
- Splash shields
- NEW** Champion Ventless Heat Recovery (*see 66 PRO-VHR spec sheet*)
- ION scale prevention device (unmounted)

Champion®

The Dishwashing Machine Specialists



**NEW PRO-90B Unloader
90° Corner Conveyor Table**

(PRO Series Rack Machines only)



**Cantilever
Sideload**

(No hood)



**Model RCT 64
or RCT 84**

Roller
Conveyor Table

02/25/2026

663781

Quote

Project: NC-Transylvania County-TC
 Henderson Elem

From: Culinary Depot
 Aaron Mensch
 67 Route 59
 Spring Valley, NY 10977
 (888) 845-8200
 845-414-5832 (Contact)

NORTH CAROLINA STATE CONTRACT # STC 5214A

Item	Qty	Description	Sell	Sell Total
1	1 ea	DISHWASHER, DOOR TYPE, VENTLESS Champion DH-6000T-VHR Genesis Dishwasher, door type, extended hood (27" opening for trays), ventless heat recovery, high temperature sanitizing with built-in stainless steel electric booster for (40°-70° rise), (40) racks/hour capacity, auto start, single point electrical connection, door interlock switch, on-board service diagnostics, Rinse Sentry feature, auto-fill, detergent & chemical connections, interchangeable upper & lower spray arms, automatic drain valve, vent fan control, bottom mounted HMI controls, mounted water PRV, stainless steel construction, electric tank heat, peg rack, flat rack, 2 HP self draining pump, side panels included, NSF, cULus, ENERGY STAR®	\$20,123.57	\$20,123.57
	1 ea	**NOTE: Please be advised that all quotes provided are valid for a period of 30 days from the date issued. Champion Industries reserves the right to make price adjustments, price increases or add surcharges as appropriate due to tariffs or market fluctuation that are out of our control. Thank you for your understanding.		
	1 ea	1 year parts & labor warranty, standard		
	1 ea	Complimentary factory authorized performance test included, upon equipment start-up. Consult local Champion sales representative for coordination of the start-up. If customer is beyond 60 miles from Champion authorized service agent, consult factory.		
	1 ea	901246 Champion ION Scale Prevention System	\$1,541.77	\$1,541.77
	1 ea	Single-point electrical connection, standard		
	1 ea	Voltage to be specified		



Attachment F

Culinary Depot

02/25/2026

Item	Qty	Description	Sell	Sell Total
	1 ea	Corner design application		
			Extended Total:	\$21,665.34
			Total	\$21,665.34

Acceptance: _____ Date: _____

Printed Name: _____

Project Grand Total: \$21,665.34

Attachment F

Champion®

The Dishwashing Machine Specialists

PROJECT: _____

ITEM # _____ QTY: _____

MODEL # _____

AIA # _____ SIS # _____

DH6000T VHR

VENTLESS HEAT RECOVERY EXTENDED HOOD-TYPE DOOR MACHINE



Rendered image is for general visual representation only. Please refer to specifications for the latest detailed product information.

OPTIONS & ACCESSORIES

- Built-in detergent and rinse aid pumps
- Drain water tampering kit (mounted)
- Racks (Peg, Flat, Sheetpan)
- Corner operation splash baffle
- Champion ION scale prevention system
- Built-In booster configured to ensure 180° rinse
- Water hammer kit (unmounted)
- Pumped drain
- Dual point electrical connection

STANDARD FEATURES

- **27" Extended Hood Clearance**
- **Ventless Heat Recovery**
- **Advanced Touchscreen Display**
intuitive condition alerts, with multi-lingual user-friendly cleaning and operational guidance
- **Enhanced Visual On-Board Diagnostics**
quickly identify machine faults for rapid resolution and less downtime
- **Energy Saving Programmable Sleep Mode**
heaters power down after user determined period of inactivity
- **Rinse Sentry**
extends wash cycle until booster reaches optimal sanitization temperature before final rinsing process
- **40 Racks Per Hour**
- **0.73 Gallons Per Rack**
- **Factory Authorized Startup**
- **Field Convertible Electrical**
ability to convert from three phase to single phase incoming power
- **Door Interlock**
ensures maximum energy recovery and limits condensation from entering the dishroom
- **Automated Delime Function**
customizable alert intervals based on site water quality
- **Field Convertible Feed Orientation**
configurable for front load, corner installation, and pass through
- **NSF Dual**
rated conforms to NSF standards for stationary rack dish machine and pot and pan machine
- **Auto Start**
machine automatically starts selected wash cycle when door is closed
- **High Efficiency 2 HP Wash Pump**
- **Automatic Drain Valve**
heavy duty, gear driven full port ball valve stainless and brass construction
- **Vent Fan, Detergent, and Rinse Aid Signal Provided**
- **Four User Selectable Wash Cycles**
users can select 1, 2, 4, and 6 minute wash cycles depending on soil load
- **Cycle Counter**
records number of cycles machine has run since installation
- **Energy Star Certified**

VENTLESS HEAT RECOVERY EXTENDED HOOD-TYPE DOOR MACHINE

SPECIFIER STATEMENT

Specified unit will be Champion model DH6000T with Ventless Heat Recovery and Condensate Removal, high temperature, high-hood type dishwashing machine. Features HMI controls, Rinse Sentry, Auto Start, up to 40 racks/hour, 0.73 US gals/rack [2.76 liters/rack, 0.61 imp. gals/rack].

1 year parts and labor warranty.



In the USA:
3765 Champion Blvd, Winston-Salem, NC 27105
Tel: (336) 661-1556 Fax: (336) 661-1979
www.championindustries.com

In Canada:
2674 N. Service Rd., Jordan Station, Ontario, Canada LOR1S0
Tel: (905) 562-4195 Fax: (905) 562-4618
www.championindustries.com/icanada

Attachment F



The Dishwashing Machine Specialists

DH6000T VHR

VENTLESS HEAT RECOVERY EXTENDED HOOD-TYPE DOOR MACHINE

Shipping weight crated: 350 lbs. Dimensions shown in inches

SPECIFICATIONS

Capacities

Racks per hr. (NSF rated) 40
Wash tank (gal.) 10

Motor Horsepower

2 HP

Water Consumption

Gal. per hr. (max. use) 39
Gal. per rack 0.73

Temperature °F

Wash 150
Rinse 180

Heating

Tank heat, electric 5.2 kW
Electric Booster 7.5 kW

Selectable cycle times in minutes	Dish-washer Mode		Pot & Pan Mode	
	1	2	4	6
Time cycles in seconds				
Wash	36	94	214	334
Rinse	8	10	10	10
Sanitary Dwell	16	16	16	16
Vent Fan	30	30	30	30
Total	90	150	270	390

Machine & Built-in Booster (Standard)

Elec. Specs	Rated Amps	Minimum Supply Ckt. Conductor Ampacity	Maximum Overcurrent Protective Device
208/60/1	72-81	100	100
208/60/3	48-50	60	60
480/60/3	21	30	30

Machine Only (two point electrical connection or no built-in booster)

Elec. Specs	Rated Amps	Minimum Supply Ckt. Conductor Ampacity	Maximum Overcurrent Protective Device
208/60/1	36-39	50	50
208/60/3	27-26	30	30
480/60/3	10	15	15

Booster Only (two point electrical connection or no built-in booster)

Elec. Specs	Rated Amps	Minimum Supply Ckt. Conductor Ampacity	Maximum Overcurrent Protective Device
208/60/1	36-42	50	50
208/60/3	21-28	30	30
480/60/3	19	15	15

Note: Water Hammer Arrestor (meeting ASSE-1010 standard or equivalent) to be supplied (by others) in common water supply line at service connection. Recommended water hardness to be 3 grains or less for optimal performance results.

Utilities

- Electrical**
Machine Connection (see electrical box)
- Cold Water**
3/4" NPT Cold Water 50° - 75°F
45 PSI dynamic incoming
Final rinse 18 PSI
- Drain**
1" NPT Connection Gravity flow
15 Drain Max Flow Rate (g/min)
- Drain Water Tempering**
1/2" Cold water line with customer supplied cut-off valve (optional)
- Integrated Detergent System**
Detergent bottle supply connections (optional)

Warning: Plumbing, electrical connections should be made by qualified personnel who will observe all the applicable plumbing, sanitary and safety codes and the National Electrical Code.

Note: Optional Drain Tempering: 3/4" NPT cold water connection required. 3/4" NPT drain connection from back flow preventer to house drain. (FIELD INSTALLED and PLUMBED).

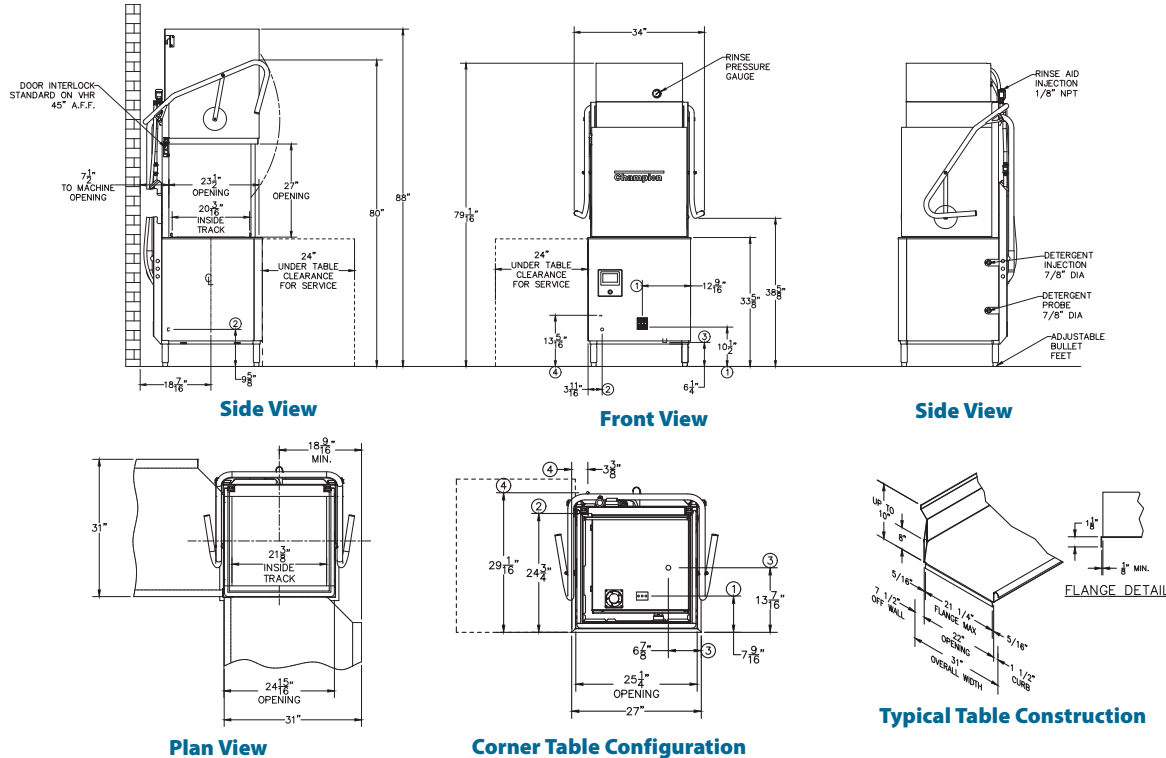

In the USA: 3765 Champion Blvd, Winston-Salem, NC 27105 | Tel: (336) 661-1556 Fax: (336) 661-1979 | www.championindustries.com

In Canada: 2674 N. Service Rd., Jordan Station, Ontario, Canada LOR1S0 | Tel: (905) 562-4195 Fax: (905) 562-4618 | www.championindustries.com/1canada

Rev. 11/2024 Printed in U.S.A.

Due to an ongoing value analysis program at Champion, specifications contained in this catalog are subject to change without notice.



Attachment G



YouTube Link



Website

March, 13, 2026

Mr. Kerry Putnam

Reference generator quote (bus garage generator)

Mr. Putnam,

PES is pleased to provide you with the following Proposal to install electrical at 749 N Country Club rd. The scope of work for this project is described below:

Scope of Work

PES plans to complete the electrical scope of work as detailed during your project review with Asahel Long.

1. PES will wire 80kw Kohler generator installed by Atlantic South. (pad included)
2. PES will install 2 automatic transfer switches in mezzanine area of shop.
3. PES will connect all 3 electrical panels in the building to new generator.
4. PES will subcontract 30'x12' concrete pad to be poured leading up to generator pad.

Clarifications / Exceptions

The following clarifications are included in your review, and were used for the basis of this proposal:

1. Work will be completed during regular hours.
2. Including all materials.
3. Including permit.
4. Including crane to set generator.
5. There may be a few week lead time on equipment.

PROPOSAL.....\$125,817.28

Please do not hesitate to contact me if you have any questions concerning this proposal. We look forward to working with you on this project.

Thank You,
Asahel Long
828-421-3090

Attachment H

Managed Generator Services LLC

8942 Quioccasin Rd

Henrico, VA 23229



Estimate

ADDRESS

Transylvania County Schools
225 Rosenwald Lane
Brevard, NC 28712

ESTIMATE # ES40378784

DATE 02/25/2026

EXPIRATION DATE 03/25/2026

ACTIVITY	DESCRIPTION	QTY	RATE	AMOUNT
KG80R; 80kw NG Generator 120/208v 3 phase	80kw NG fueled generator, aluminum sound/weather resistant enclosure, 208v, 3 phase. Battery charger, block heater, 5 yr. basic warranty	1	34,299.00	34,299.00T
Equipment Rental	boom truck or telehandler to remove existing generator and set new generator	1	1,500.00	1,500.00T
Labor Rate	Disconnect gas and electrical from existing generator. Remove from pad. Set new generator on existing pad. Plumb gas and tie in electrical load leads and comm wires/dc wiring. perform factory start up/warranty commissioning. Perform loaded test with available building load if allowed 2 technicians for this work	20	157.50	3,150.00T
Gas Pipe	Gas Pipe and misc fittings	1	129.95	129.95T
RV61 Maxitrol 1.25" Gas Regulator	1-1/4" Straight-Thru-Flow Gas Regulator (2,500,000 BTU)	1	187.10	187.10T
Electric Wire & Conduit	Wire, Conduit, and other materials for electrical installation	1	125.00	125.00T
Materials, Shop and Environmental Fee	Material and Environmental Fee	1	129.45	129.45T
Trip Charge- (176 - 200 miles)	Delivery to jobsite.	1	1,200.00	1,200.00

Spec sheet and drawing attached.
Current lead time is 6-7 weeks from date of order.

SUBTOTAL	40,720.50
TAX	2,748.63
TOTAL	\$43,469.13

Accepted By

Accepted Date

All bills not paid within thirty days (30) of invoice due date, will be assessed a late charge of 1.5% per month on the unpaid balance until paid in full.

Prepared For
Transylvania County Schools
Blake Tesnow
225 Rosenwald Lane
Brevard, NC 28712
btesnow@tcsnc.org
(828) 884-6173

Prepared By
Jennifer Stone
Phone: 864-326-3572
Email: jstone@encoretg.com

Hardware		Price	Qty	Extended
WA75F	Display Diagonal Size: 74.5Inch - 3840 x 2160 - 400cd/m2 - Display / Response Time: 8 - 16:9 - 800 x 400 mm - All-in-One Digital Android Based Interactive Display Display Diagonal Size: 74.5Inch - 3840 x 2160 - 400cd/m2 - Display / Response Time: 8 - 16:9 - 800 x 400 mm - All-in-One Digital Android Based Interactive Display	\$1,650.77	100	\$165,077.00
Hardware Subtotal				\$165,077.00

Recap	Amount
Hardware	\$165,077.00
Subtotal	\$165,077.00
Tax	\$11,142.70
Total	\$176,219.70

Based on the rapidly changing market, availability, lead times, and potential tariffs are all possibilities. Please note that pricing and availability are subject to change. Encore will notify client of any changes in availability, pricing, or fees (tariffs, surcharges, shipping, etc.) as we are made aware.

Currently, some manufacturers are requiring non-cancellation clauses on purchase orders. For those orders, Encore may also require a non-cancellation clause to be signed before an order can be processed.

All sales are exclusively subject to and conditioned upon the terms and conditions of sale posted at <http://www.encoretg.com/terms-and-conditions>, and any other additional or different terms are objected to and rejected unless Encore expressly agrees to them in a signed writing.

Signature

Date



Bill to Transylvania County Schools Customer No: 85466 225 Rosenwald Lane Brevard NC 28712 USA	Ship to Transylvania County Schools 225 Rosenwald Lane Brevard NC 28712 USA 828-884-6173	Quote Details Created: February 13, 2026 Expiration: February 20, 2026 Created by: Marie Muenchow marie.muenchow@trafera.com
Estimate No: E000166363		

Contract
 Lenovo NC 204A Statewide Term Contract ITS-400203

Products & Services

Items and Descriptions	Overview	Notes	Qty	Unit Price	Totals
100E G5 TS MT8189 4G 64G SSD 11"	Lenovo 100e Gen 5 Chromebook – 11.6" WXGA (1366 x 768) Touch – MediaTek Kompanio 540 (MT8189) – 4GB LPDDR5X SDRAM – 64GB UFS – Integrated Graphics – IEEE 802.11ax – Bluetooth 5.3 – HD Webcam + Microphone – ChromeOS – 1 Year Mail-in		650	\$499.00	\$324,350.00
Warranty L3W	Trafera Support for Lenovo Chrome		650	\$0.00	\$0.00
Trafera CBN Warranty – Plat – 4 Yr – C	Trafera CBN Warranty – Plat – 4 Yr – Includes Accidental Damage Protection (Per device limit of ADP: Unlimited) – \$0.00 Deductible – Hardware Fail Covered – Spare Parts On-site (restrictions apply) – We Pay to Ship Both Ways – Theft / Loss (up to 2%; please see warranty statement for details) – 3-Year Battery warranty on New Chrome devices (Limit 1 replacement) – Stylus/EMR Pen/Apple Pencil coverage (restrictions apply) – Power Adapter 1 ADP Incident (restrictions apply)		650	\$0.00	\$0.00
TRAILS AI Lesson Studio – 1 Yr Sub	TRAILS is an elite lesson plan generator that builds sophisticated, tech-infused lesson plans in seconds. Leveraging Google Gemini and incorporating the SAMR model to ensure high-impact learning, TRAILS lessons maximize the technology and tools teachers already have in their classrooms.		1	\$0.00	\$0.00
Trafera Preconfigure Customer WiFi	"Trafera Pre-Configure WiFi – Pre-configure device to automatically connect to a managed network"		650	\$0.00	\$0.00

Attachment I

Lift Gate on Truck	"Lift Gate on Truck - Liftgate service provided at time of delivery - Required for heavy or bulky items if loading dock is not present at delivery location"	1	\$0.00	\$0.00	
Trafera Chrome White Glove	Trafera White Glove - Pre-enroll Chrome device in Google Apps® domain - Apply custom themes and settings - Complete hardware functionality check - Google Console OU management"	650	\$0.00	\$0.00	
Google Chrome Management Perpetual EDU	Google Chrome Management Perpetual EDU License	650	\$0.00	\$0.00	

Subtotal \$324,350.00

Tax \$21,893.63

Total **\$346,243.63**

Net Terms **N30**

Terms and Conditions

This quote is confidential and is to be viewed solely by individuals within the organization to whom it is addressed. Unauthorized distribution or disclosure of the contents of this quote is prohibited. If you are not from the organization addressed, please notify us immediately so we can prepare a quote specific to you. Prices and availability may change without notice prior to the quote expiration date due to market conditions, including potential tariff adjustments and available inventory.

Please Remit Checks to:

Trafera LLC
PO Box 208960
Dallas, TX 75320-8960

Questions? Contact me

Chad Dehmlow
chad.dehmlow@trafera.com



Trafera
1271 Red Fox Rd.
Arden Hills MN 55112
United States

For quick details on returns, learn more here → <https://www.trafera.com/return-policy>

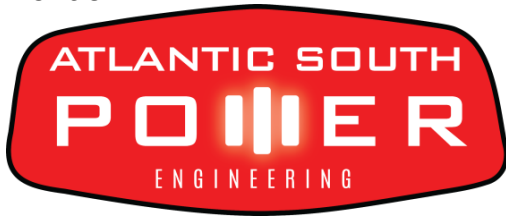

Matt Crook | President
Cell 828-713-8359 | Toll Free 844-697-6937 (69 POWER)
240 Wright Brothers Way, Fletcher, NC 28732
matt@atlanticsouthpower.com

To: David McNeill
Re: Install Means of Disconnect
Ad: Brevard Highschool Baseball Field

Date: 04/02/2026
Quote # 07532-26

Atlantic South Power Engineering (ASPE) agrees to provide all material and labor necessary to perform the following work:

- ASPE shall install (2) 100amp disconnects and (4) 125amp disconnects.
- ASPE shall rewire existing breakers and lighting branch circuits in order to provide a safe means of disconnect.
- ASPE will install all raceways and wire needed.
- Raceways will be NEC approved and all wire shall be copper.

CONTRACT PRICE:	\$ 10,356.00
TAXES:	\$ 699.03
TOTAL:	\$ 11,055.03



DATE: 4/14/2026

Transylvania County Schools
400 Rosenwald Lane
Brevard NC 28712

ATTN: Kerry Putnam

PROJECT: TCS - Brevard High School
Detection Device Replacements

LOCATION: Brevard High School
609 N. Country Club Rd.
Brevard, NC 28712

PROPOSAL #: 26-2708

MSS Fire & Security, LLC proposes to provide labor, material, and equipment to perform the work described below for the net price of:

Thirty Three Thousand Eight Hundred Twelve Dollars..... \$33,812.00 USD

For the above price, this proposal includes:

- MSS Scope of work is to replace all smoke/heat detection devices at Brevard High School with Flashscan compatible devices. MSS will provide and install all devices in accordance with drawings, specifications (if received), and national/local codes and ordinances.
- Total device count includes 162 smoke heads (156 Smoke Detectors + 6 Duct Detectors) and 23 heat heads.
- MSS will remove and dispose of old devices, as well as install, program and label all new devices. Testing certification and one inspection with the AHJ is also included. Additional inspections required due to other trades may result in additional charges, not included in base pricing above.

QUANTITY	DESCRIPTION
156	INTELLIGENT ADDRESSABLE PHOTO DETECTOR; WITH FLASHSCAN; WHITE
23	INTELLIGENT ADDRESSABLE 135 DEGREE THERMAL DETECTOR WITH FLASHSCAN; WHITE
19	INTELLIGENT FLANGED MOUNTING BASE; 6" INCH; PACK OF 10; WHITE
6	REMOTE TEST CAPABLE INTELLIGENT PHOTO DETECTOR WITH FLASHSCAN; FOR USE WITH DNR(W) DUCT DETECTOR HOUSING; WHITE
6	INNOVAIRFLEX INTELLIGENT DUCT DETECTOR, NON-RELAY, DOES NOT INCLUDE HEAD.
6	INNOVAIRFLEX SAMPLING TUBE, STEEL, 5' WITH HOLES

Clarifications:

Ask about our Sustainability services!

- All work is to be performed during normal business hours. Overtime is not included.
 - Any scope not mentioned above is not included. 120v power, Conduit, Boxes and Pathway support straps are not included under this scope.
 - Total Job tax is included on this proposal.
 - IF APPLICABLE: NC DOR E-589CI Affidavit of Capital Improvement must be received with purchase order or contract.
 - Upon receipt of valid E-589CI Affidavit of Capital Improvement, a credit can be issued in the amount of: **\$487.44**
-

Ask about our Sustainability services!



Signatures:

IMPORTANT:

- SALES TAX IS INCLUDED IN THE ABOVE AMOUNTS UNLESS AN NCDOR E-589CI AFFIDAVIT OF CAPITAL IMPROVEMENT FORM IS SIGNED & RECEIVED WITH PURCHASE ORDER OR CONTRACT.

- THE ABOVE PRICE, DELIVERY/PERFORMANCE DATE, AND/OR TIME TO COMPLETE THE SCOPE OF WORK ARE SUBJECT TO CHANGE DUE TO LABOR SHORTAGES, SUPPLY CHAIN ISSUES, MATERIAL SURCHARGES AND/OR COVID-19 RELATED PROTOCOLS. THIS SPECIFICALLY INCLUDES SURCHARGES DUE TO THE U.S. GOVERNMENT TARIFF IMPOSED ON IMPORTED MATERIAL AND EQUIPMENT.

This proposal is subject to MSS Standard Terms and Conditions of Sale effective on the date of the proposal, which are incorporated in full by this reference. The MSS Standard Terms and Conditions of Sale are available upon request, attached hereto, and/or can be found on <https://msssolutions.com/terms>. Any conduct by Purchaser which recognizes the existence of a contract pertaining to this proposal shall be considered acceptance of this proposal and all of its terms and conditions. This proposal is hereby accepted and MSS is authorized to proceed with the work; subject, however to credit approval by MSS.

Purchaser: _____

Seller: MSS Fire & Security, LLC

Signature: _____

Signature: _____

Name: _____

Name: Chad Penley

Title: _____

Title: Account Manager

Date: _____

Date: 04/14/2026

PO: _____

MSS Office: 125 Glenn Bridge Road,
Arden, NC 28704

MSS Licenses: NC # 16306
#729-CSA
SC #EL5-M111768
#FAC-13787
#BAC-13856



E-589CI Affidavit of Capital Improvement

Form E-589CI, Affidavit of Capital Improvement, is generally required to substantiate that a contract, or a portion of work to be performed to fulfill a contract, is to be taxed for sales and use tax purposes as a real property contract with respect to a capital improvement to real property.

- This affidavit may not be used to purchase building materials, other tangible personal property, or digital property to fulfill a real property contract exempt from sales and use tax.
- A person who willfully attempts, or a person who aids or abets a person to attempt in any manner, to evade or defeat a tax imposed by the Sales and Use Tax Laws, or the payment thereof, shall be guilty of a Class H felony. If there is a deficiency or delinquency in payment of any tax due to fraud with intent to evade the tax, there shall be assessed a penalty equal to 50% of the total deficiency.

Section I. Single Use (Complete this section to issue the affidavit for a single capital improvement.)

<p>A Owner, Tenant, or Real Property Contractor</p> <p>Address</p> <p>City State Zip Code</p>	<p>B Real Property Contractor (General Contractor or Subcontractor) <small>Hired to perform capital improvement</small></p> <p>Address</p> <p>City State Zip Code</p>
--	--

Describe capital improvement to be performed:

Project Name

Project Address (where the work is to be performed) City State Zip Code

I certify that, to the best of my knowledge, this affidavit is accurate and complete and that the transaction described to be performed by the Real Property Contractor (General Contractor or Subcontractor identified in box "B") shall be treated as a real property contract with respect to a capital improvement to real property for sales and use tax purposes.

Signature of Authorized Person: _____ Title: _____ Date: _____

Section II. Blanket Use (Complete this section execute a blanket affidavit.)

<p>C Real Property Contractor</p> <p>Address</p> <p>City State Zip Code</p>	<p>D Real Property Contractor or Subcontractor <small>Hired to perform capital improvement</small></p> <p>Address</p> <p>City State Zip Code</p>
--	---

To be completed by the Real Property Contractor Identified in Box C.

I certify that I am a Real Property Contractor who performs capital improvements to real property and all transactions with the real property contractor (subcontractor) identified in box "D" shall be treated as real property contracts with respect to capital improvements for real property for sales and use tax purposes.

Signature of Authorized Person: _____ Title: _____ Date: _____

Ask about our Sustainability services!